

# Hydraulics & Pneumatics®

THE AUTHORITY ON FLUID POWER TECHNOLOGY

OCTOBER 2020 [hydraulicspneumatics.com](http://hydraulicspneumatics.com)

## **BUFFER SEALS PROTECT**

*Industrial  
Hydraulics*  
12

Introducing  
**H&F**Connect  
8

**DOING OUR BEST TO FLATTEN  
THE CURVE**



***Tompkins***<sup>®</sup>  
INDUSTRIES, INC.

WE'RE WORKING TODAY FOR A  
BETTER TOMORROW

800-255-1008 | [tompkinsind.com](http://tompkinsind.com)



# High Performance Fluid Power



## System Saver

(Pumps with factory fitted flange mounted valving kits that save you space, costs and time)



## VC5 Check Valve

Series : VC5 V06, V08, V10, V12, V16,  
Size : 3/4", 1", 1 1/4", 1 1/2", 2" (20, 25, 32, 38, 50 mm)  
Flow : 26, 53, 106, 198, 198 gpm / 100, 200, 400, 750, 750 lpm  
Pressure: 3050 psi / 210 bar  
Mounting : Flange (Poppet & Ball Type)

\* V - Relief, U - Unloader, S - Sequence, R - Reducing

## VR4 Valve

Series : VR4 03, VR4 06, VR4 10  
Size : 3/8", 3/4", 1 1/4" (10, 20, 32 mm)  
Flow : 24, 80, 159 gpm, 90, 300, 600 lpm  
Pressure: 5000 psi / 350 bar  
Mounting : Subplate / Threaded / Cartridge

Please contact us:

## Veljan Hydrair Inc.

Sales & Warehouse: 4034, Chamblee Road,  
Oakwood, GA 30566 (USA). Phone: 877.793.6405  
Website : [www.veljan.in](http://www.veljan.in) | E-mail : [sales@veljanusa.com](mailto:sales@veljanusa.com)

We help you see your ideas work



# IN THIS ISSUE

## FEATURES

- 12 How Buffer Rod Seals Influence Rod Seal Performance**  
In Part 1 of this article, tests reveal how these two seals interact to affect friction and seal life. But first, a look at buffer seals.
- 16 How Bode Plots Describe Servo Valves Specifications**  
Engineers should know and understand Bode plots to make the best of their valve decisions.
- 20 Hydraulic Locks Protect Against Unplanned Moves and Dropped Loads**  
Even better, they add a level of safety to critical applications.
- 24 Piezo-Electric Valves for Hydraulic and Pneumatic Systems**  
Piezo actuators provide a combination low power, low weight and accuracy.
- 32 Advanced Hydraulics and Controls Make Calendering More Precise and Efficient**  
The precision and stability of the hydraulics and controls make them a more accurate and reliable way to handle calendering.



## DEPARTMENTS

- 6 EDITOR'S PAGE**
- 8 INDUSTRY NEWS**
- 30 USEFUL PRODUCTS**
- 31 ADVERTISERS INDEX**



30

JOIN US ONLINE



twitter.com/H\_and\_P\_knows  
facebook.com/HydraulicsPneumatics



ISSN 0018-814X  
Printed in U.S.A. Copyright © 2020 by Endeavor Business Media, all rights reserved. *Hydraulics & Pneumatics* is published monthly, except for a combined issue in May/June and November/December, by Endeavor Business Media, 1233 Janesville Ave., Fort Atkinson, WI 53538. Phone: 216-696-7000. Periodicals postage paid at Fort Atkinson, WI and at additional mailing offices. **POSTMASTER:** Send address changes to *Hydraulics & Pneumatics*, PO Box 3257, Northbrook, IL 60065-3257. Copying: permission is granted to users registered with the Copyright Clearance Center Inc. (CCC) to photocopy any article provided base fee of \$1.25 per copy of the article plus 60¢ per page is paid directly to CCC, 222 Rosewood Dr., Danvers, MA 01932 (Code No. 0018-814X/00 \$1.25 + 60¢).

Subscriptions — U.S. and possessions outside U.S.: \$60/yr; \$90/two yrs. Single copies: \$10.00 each. In Canada: \$70.00/yr; \$110.00/two yrs. Canadian GST #R126431964. International: \$90.00/yr; \$140.00/two yrs. To order, phone 847-763-9670. Fax orders to 847-763-9673. Send subscription payment to: *Hydraulics & Pneumatics*, PO Box 3257, Northbrook, IL 60065-3257. Out-of-print copies available in complete volumes as positive microfilm from NAPCO 800-420-6272 x 6578. Photocopies of articles \$5.00 each. Payment must accompany request. Volume 73, No. 9, October 2020.



**Diessa Rubber Hoses.**  
**Part of your world.**

**EVERYDAY BY YOUR SIDE TO MASTER THE TOUGHEST CHALLENGES**

X FIGHT 4000 - 5000 - 6000 and 4SH are spiral hoses that offer measurably greater advantages in routing and installation. These latest-generation hoses provide excellent performance to meet the most demanding customer needs including ABS, MED and USCG certified marine applications.

Via Provinciale 8, SP 155 - Filago (BG) - ITALY - Phone: +39 (035) 49.42.300 | [www.dieaserubber.com](http://www.dieaserubber.com) [sales@dieaserubber.com](mailto:sales@dieaserubber.com)

**DIESE**  
DIESE RUBBER HOSES  
MADE IN ITALY

United States Postal Service		
Statement of Ownership, Management, and Circulation	(Requester Publications Only)	
1. Publication Title: <i>Hydraulics &amp; Pneumatics</i>		
2. Publication Number: 254-960		
3. Filing Date: 9/3/20		
4. Issue of Frequency: Monthly, except for a combined issue in May/June & Nov/Dec		
5. Number of Issues Published Annually: 10		
6. Annual Subscription Price: Free to Qualified		
7. Complete Mailing Address of Known Office of Publication (Not Printer): Endeavor Business Media, LLC, 1233 Janesville Ave, Fort Atkinson, WI 53538	Contact Person: Debbie M Brady Telephone: 941-208-4402	
8. Complete Mailing Address of Headquarters or General Business Office of Publisher (Not Printer): Endeavor Business Media, LLC, 331 54th Ave N., Nashville, TN 37209		
9. Full Names and Complete Mailing Addresses of Publisher, Editor, and Managing Editor - Publisher: Tracy Smith, Endeavor Business Media, 331 54th Avenue N., Nashville, TN 37209 - Editor: Bob Vavra, Endeavor Business Media, 331 54th Avenue N., Nashville, TN 37209 ; Managing Editor: ,		
10. Owner - Full name and complete mailing address: Endeavor Media Holdings I, LLC, 905 Tower Place, Nashville, TN 37205; Endeavor Media Holdings II, LLC, 905 Tower Place, Nashville, TN 37205		
11. Known Bondholders, Mortgagees, and Other Security Holders Owning or Holding 1 Percent or More of Total Amount of Bonds, Mortgages or Other Securities: None		
12. Tax Status (For completion by nonprofit organizations authorized to mail at nonprofit rates) (Check one) The purpose, function, and nonprofit status of this organization and the exempt status for federal income tax purposes: N/A		
13. Publication Title: <i>Hydraulics &amp; Pneumatics</i>		
14. Issue Date for Circulation Data: August 2020	Average No. Copies Each Issue During	
15. Extent and Nature of Circulation	Preceding 12 Months	
a. Total Number of Copies (Net press run)	27,873	
	No. Copies of Single Issue Published Nearest to Filing Date	
	28,281	
b. Legitimate Paid and/or Requested Distribution (By Mail and Outside the Mail)		
(1) Outside County Paid/Requested Mail Subscriptions stated on PS Form 3541. (Include direct written request from recipient, telemarketing and Internet requests from recipient, paid subscriptions including nominal rate subscriptions, employer requests, advertiser's proof copies, and exchange copies.)	25,540	25,587
(2) In-County Paid/Requested Mail Subscriptions stated on PS Form 3541. (Include direct written request from recipient, telemarketing and Internet requests from recipient, paid subscriptions including nominal rate subscriptions, employer requests, advertiser's proof copies, and exchange copies.)	0	0
(3) Sales Through Dealers and Carriers, Street Vendors, Counter Sales, and Other Paid or Requested Distribution Outside USPS®	675	705
(4) Requested Copies Distributed by Other Mail Classes Through the USPS (e.g. First-Class Mail®)	0	0
c. Total Paid and/or Requested Distribution (Sum of 15b (1), (2), (3), and (4))	26,215	26,292
d. Nonrequested Distribution (By Mail and Outside the Mail)		
(1) Outside County Nonrequested Copies Stated on PS Form 3541 (include Sample copies, Requests Over 3 years old, Requests induced by a Premium, Bulk Sales and Requests including Association Requests, Names obtained from Business Directories, Lists, and other sources)	860	1,377
(2) In-County Nonrequested Copies Stated on PS Form 3541 (include Sample copies, Requests Over 3 years old, Requests induced by a Premium, Bulk Sales and Requests including Association Requests, Names obtained from Business Directories, Lists, and other sources)	0	0
(3) Nonrequested Copies Distributed Through the USPS by Other Classes of Mail (e.g. First-Class Mail, Nonrequestor Copies mailed in excess of 10% Limit mailed at Standard Mail® or Package Services Rates)	0	0
(4) Nonrequested Copies Distributed Outside the Mail (Include Pickup Stands, Trade Shows, Showrooms and Other Sources)	132	0
e. Total Nonrequested Distribution (Sum of 15d (1), (2), (3), and (4))	992	1,377
f. Total Distribution (Sum of 15c and 15e)	27,207	27,669
g. Copies not Distributed	666	612
h. Total (Sum of 15f and g)	27,873	28,281
i. Percent Paid and/or Requested Circulation (15c divided by 15f times 100)	96.35%	95.02%
16. Electronic Copy Circulation		
a. Requested and Paid Electronic Copies	-	-
b. Total Requested and Paid Print Copies (Line 15c)+ Requested/Paid Electronic Copies (Line 16a)	26,215	26,292
c. Total Requested Copy Distribution (Line 15f) + Requested/Paid Electronic Copies (Line 16a)	27,207	27,669
d. Percent Paid and/or Requested Circulation (Both Print & Electronic Copies) (16b divided by 15c x 100)	96.35%	95.02%
e. <input type="checkbox"/> I certify that 50% of all my distribution copies (electronic and print) are legitimate requests or paid copies:		
17. Publication of Statement of Ownership for a Requester Publication is required and will be printed in the:	issue of this publication.	Oct-20
18. _____	Date	
Debbie M Brady, Manager User Marketing		9/3/20

I certify that all information furnished on this form is true and complete. I understand that anyone who furnishes false or misleading information on this form or who omits material or information requested on the form may be subject to criminal sanctions (including fines and imprisonment) and/or civil sanctions (including civil penalties).

EDITORIAL

SENIOR CONTENT EDITOR: **BOB VAVRA** bvavra@endeavorb2b.com  
 MANAGING EDITOR: **JEREMY COHEN** jcohen@endeavorb2b.com  
 SENIOR EDITOR: **STEPHEN J. MRAZ** smraz@endeavorb2b.com  
 SENIOR EDITOR: **REHANA BEGG** rbegg@endeavorb2b.com  
 SENIOR EDITOR: **MARIE MCBURNETT** mmburnett@endeavorb2b.com  
 CONTRIBUTING TECHNICAL EXPERT: **PETER NACHTWEY** peter@deltamotion.com  
 CONTRIBUTING TECHNICAL EXPERT: **ROBERT J. SHEAF, JR.** rjsheaf@cfcsolar.com  
 CONTRIBUTING EDITOR: **RAY SCROGGINS** ray@scroggins.biz  
 CONTRIBUTING EDITOR: **TOM ANDEL** tandel4315@aol.com

ART DEPARTMENT

GROUP DESIGN DIRECTOR: **ANTHONY VITOLO** hvitolo@endeavorb2b.com  
 ART DIRECTOR: **JOCELYN HARTZOG** jhartzog@endeavorb2b.com

PRODUCTION

GROUP PRODUCTION DIRECTOR: **GREG ARAUJO** garaujo@endeavorb2b.com

CIRCULATION LIST RENTALS & CUSTOMER SERVICE

USER MARKETING MANAGER: **DEBBIE BRADY** dbrady@endeavorb2b.com  
 REPRINTS: reprints@endeavorb2b.com  
 LIST RENTAL / SMARTREACH CLIENT SERVICES MANAGER: **MARY RALICKI** mralicki@endeavorb2b.com  
 FREE SUBSCRIPTION / STATUS OF SUBSCRIPTION / ADDRESS CHANGE / MISSING BACK ISSUES: **OMEDA** T | 847.513.6022 TOLL FREE | 866.505.7173 F | 847.291.4816 | hydraulicspneumatics@omeda.com

SALES REPRESENTATIVES

NORTH AMERICA ACCOUNTS MANAGER: **RONALD KLIMKO** rklimko@endeavorb2b.com  
 INTERNATIONAL SALES  
 ITALY: **DIEGO CASIRAGHI** diego@casiraghi-adv.com  
 GERMANY, AUSTRIA, SWITZERLAND: **CHRISTIAN HOELSCHER** christian.hoelscher@highcliffmedia.com  
 BELGIUM, NETHERLANDS, LUXEMBURG, UNITED KINGDOM, SCANDINAVIA, FRANCE, SPAIN, PORTUGAL: **LARA PHELPS** lara.phelps@highcliffmedia.com  
 PAN ASIA: **HELEN LAI** helen@twayway.com

DIGITAL

SENIOR DIGITAL INNOVATION & STRATEGY DIRECTOR: **RYAN MALEC** rmalec@endeavorb2b.com

DESIGN & ENGINEERING GROUP

EVP, DESIGN & ENGINEERING GROUP: **TRACY SMITH** tsmith@endeavorb2b.com  
 GROUP CONTENT DIRECTOR: **MICHELLE KOPIER** mkopier@endeavorb2b.com  
 VP OF MARKETING SOLUTIONS: **JACQUIE NIEMIEC** jniemiec@endeavorb2b.com

ENDEAVOR BUSINESS MEDIA, LLC

331 54th Ave N., Nashville, TN 37209 USA | www.endeavorbusinessmedia.com  
 CEO: **CHRIS FERRELL**  
 CRO/CMO: **JUNE GRIFFIN**  
 CFO: **WILLIAM NURTHEN**  
 COO: **PATRICK RAINS**



CHIEF ADMINISTRATIVE AND LEGAL OFFICER: **TRACY KANE**

EVP KEY ACCOUNTS: **SCOTT BIEDA**  
 EVP SPECIAL PROJECTS: **KRISTINE RUSSELL**

Electronic Design | Machine Design | Microwaves & RF | Hydraulics & Pneumatics | Source ESB | Source Today | Evaluation Engineering

# Rodless Air Cylinders

Half the Footprint, 100% of the Value

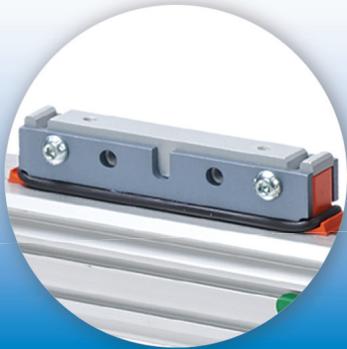

**L-SERIES  
CYLINDERS**  
STARTING AT  
**\$215.00**  
(L16M0100MD-MC)



## L-Series Rodless Air Cylinders

Rodless air cylinders are robust and compact linear actuators powered by a pneumatic air supply and controlled the same way as a conventional air cylinder. Rodless cylinders can offer the same stroke length as rodded cylinders in a smaller space. All sizes have magnetic pistons and are double acting. NITRA L-Series double-acting rodless cylinders are typically half the cost of those offered by competitors and can be used in place of typical air cylinders or even traditional motion equipment.

### Features

- Rodless cylinder design
- Double acting with magnetic piston
- Front and rear adjustable cushions
- Tapped end caps mount
- 16mm to 40mm bore sizes available
- 100mm to 1000mm stroke lengths available
- 2-Year warranty

### Rodless Air Cylinders

### AutomationDirect NITRA Series Price/Part Number

VS.

### Grainger SPEEDAIRE Price/Part Number

**Pneumatic air cylinder, rodless**  
25mm bore, 300mm stroke

**\$272.00**  
L25M0300MD-MC



**\$507.00**  
3FE23



**Pneumatic air cylinder, rodless**  
40mm bore, 300mm stroke

**\$361.00**  
L40M0300MD-MC



**\$768.00**  
3FE36



All prices are U.S. published prices. AutomationDirect prices as of 4/17/2020. Prices and specifications may vary by dealer. Grainger prices are from <http://www.grainger.com> 4/17/2020 Prices subject to change without notice.

Research, price, buy at: [www.automationdirect.com/rodless-air-cylinders](http://www.automationdirect.com/rodless-air-cylinders)

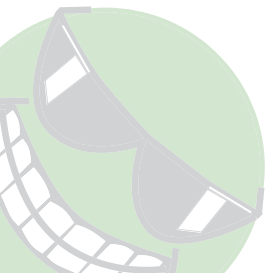

Order Today, Ships Fast!

\* See our Web site for details and restrictions. © Copyright 2020 AutomationDirect, Gannett, GA, USA. All rights reserved.



**AUTOMATIONDIRECT**.com  
1-800-633-0405

the #1 value in automation



## Editor's Page

BOB VAVRA | Senior Content Director | bvavra@endeavorb2b.com

# It's Simple: Focus on Fundamentals

THERE IS A small plaque inside our home that reads "Live Simply." As we've strived to adapt our work and our lives to the profound changes of this extraordinary year, that one phrase keeps echoing in my head. In a complicated, conflicted world, the notion that simplifying things will make it all better might seem either naïve or, if you'll pardon a turn of phrase, too simple.

But because complexity isn't going away any time soon, how do we deal with change in a way that helps us not just confront it, but conquer it? I think it starts with fundamentals.

Look at the technology advances we embrace each day. There are new ways to measure and manage systems, new sensors to deploy in new ways, new software to turn that sensor data into action. Yet at their core, these "new" systems are simply upgrades to past technologies and techniques that have been part of our operations for decades.

Temperature is a good example. We've learned over time that excessive heat is the enemy of hydraulic systems. What is excessive? Over time, we measured and examined our systems and narrowed down the definitions. We've used increasingly sophisticated systems to hone in on current-state temperature with accuracy, and we've been able to trend that data to better predict when systems needed lubrication, repair or overhaul.

The goal of all of this is not to add more technology, but to determine the temperature. Viewed in this light, the technology itself isn't the end, but the means to answer the fundamental question.

In the classic *Hitchhiker's Guide to the Galaxy* series, a supercomputer was developed to determine the answer to "the ultimate question of life, the universe and everything." After 7 million years of calculations, the computer determined answer was "42." When complaints were raised as to the meaning of the answer, the supercomputer noted that the answer was right, but the problem was that no one knew what the question actually was. Another computer had to be developed to figure out the actual question. I won't spoil the outcome of that effort; you'll have to read all five parts of the series.

Too often we expect the technology itself to be the solution. If we stop to ask ourselves what question we are trying to answer, our tools become more valuable. Our technology becomes a way to find greater simplicity.

I mention that as we start a two-part series on buffer seals this month. It's hardly a sexy technology and, as we've discovered, a little challenging to illustrate. As you'll learn during this series, what buffer seals do is fundamental to the proper performance of hydraulic cylinders. It's as simple as that. 



HOSE REELS - CABLE REELS - SWIVEL JOINTS

## WAKE UP! GET BACK TO REALITY

Dreams are not reel, it can be real.



Management system certified in accordance with the requirements of ISO 9001 - ISO 14001 - OHSAS 18001



Anytime. Anywhere. **Always here.**

Hose and Reel Accessories



MotionIndustries.com

# NEWS

## H&P CONNECT LAUNCH Offers Interactive Directory

This new supplier and distributor directory is an invaluable online resource for products.

The launch of *H&P Connect*, the new interactive supplier and distributor tool on the *Hydraulics & Pneumatics* home page, offers suppliers a new way to showcase their products and services to the global *H&P* audience and a convenient way for end-users to easily find and source thousands of products with one click.

The free website tool allows listing updates at any time. This creates a comprehensive directory of suppliers and distributors that remains fresh and current. Suppliers and distributors can list their address and up to three product categories.

An Enhanced listing allows suppliers and distributors to expand that listing for an annual fee. Among the enhancements are company logos, unlimited category listings, a link to your website and links to the library of *H&P* articles throughout the year.

"*H&P Connect* will become the source used by fluid power product specifiers around the world," said senior content director Bob Vavra. "For hydraulics and pneumatics suppliers and distributors, *H&P Connect* is not only a convenient way to put their name and capabilities in front of this audience, but it offers them a way to stay connected with their customers when new products are available. *H&P Connect* will be continually refreshed, making it a useful resource for the hydraulics and pneumatics professional."

## H&P Connect

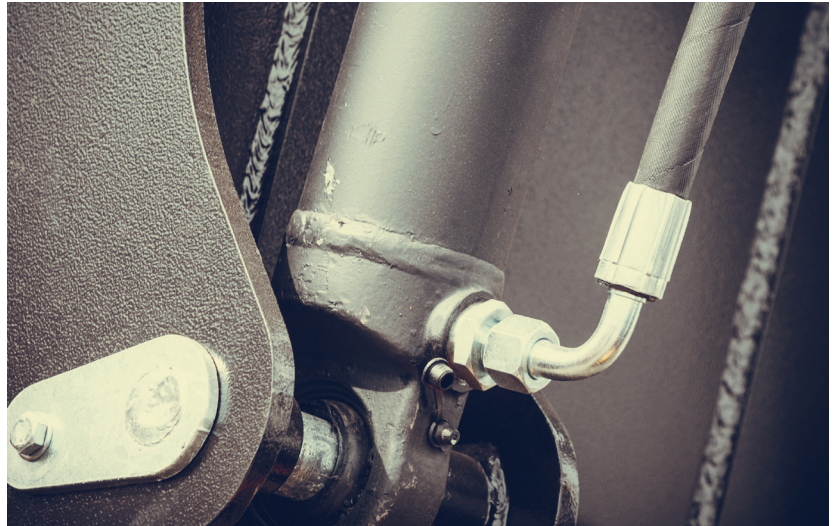

Beyond just names and addresses, *H&P Connect's* interactive portal offers a new way to search for your solutions by product category. End-users also can find videos, links to social media accounts, and product and service overviews from those suppliers and distributors who subscribe to the enhanced package.

"We've constructed *H&P Connect* to make it a valuable database for our global audience and an easy, powerful way for suppliers and distributors to put themselves in front of that audience," Vavra said. "We expect *H&P*

*Connect* to be a tool that will grow more valuable every day as more readers use its powerful search tool and more suppliers and distributors use that tool to highlight the great innovations in our industry." ■

TO FILL OUT THE FORM to be included in *H&P Connect*, visit <https://form.jotform.com/202247004533140>.

FOR MORE INFORMATION about the *H&P Connect* enhanced program, contact North American Accounts Manager Ron Klimko at [rklimko@endeavorb2b.com](mailto:rklimko@endeavorb2b.com).



---

## Building better motors

For more than 100 years

More than 100 years ago, we set out to “build a better motor.” Today, as part of ABB, our goal remains the same as we invest in revolutionary designs, technologies, processes, and tools in order to take better care of our customers.

The updated Baldor-Reliance® logo reminds us of our innovative history and stands for all that we can accomplish as we build better motors for an even better future.

**Safe. Reliable. Efficient.**

[baldor.abb.com](http://baldor.abb.com)



Order the new 501 here



## NAHAD OFFERS ONLINE TRAINING, Certification on Hose Fabrication

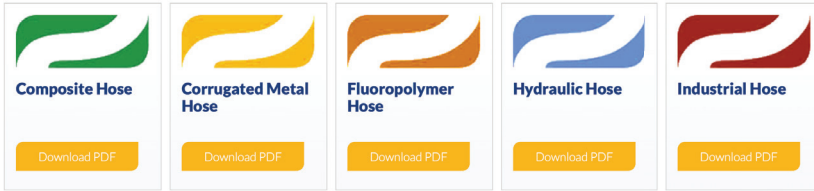

**AN UPDATED E-LEARNING PLATFORM** has been created for members of NAHAD - The Association for Hose and Accessories Distribution. The online course will provide training and certification on the proper methods and techniques for hose fabrication. After successfully completing the course materials, students will be certified for up to three years in hose fabrication best practices.

“NAHAD members deserve not only the best industry training, but also state-of-the-art and conveniently accessible applications, handbooks and e-learning programs to further their education and CE requirements,” said NAHAD executive vice president Molly Alton Mullins. “NAHAD offers its members many educational opportunities, including regional training. This, combined with the power of NAHAD Academy and the recently re-released Fabrication Guides and courses, affords members anytime, anywhere access to quality and relevant digital training.”

The NAHAD’s Hose Assembly Fabrication Guides and courses cover industry regulations and requirements for the assembly and application of composite, hydraulic, corrugated, industrial and fluoropolymer hose types. Three of the five e-learning courses—Composite Hose, Corrugated Metal Hose and Hydraulic Hose—are now available. Course on Industrial Hose and Fluoropolymer Hose are expected to follow in October. NAHAD will also provide Spanish translations for hydraulic and industrial fabrication courses later in October.

“We are excited about the long-awaited update and release of the Fabrication Guides and courses on NAHAD Academy,” said Joanna Truitt, NAHAD’s director of training, and the Hose Safety Institute. “They truly are a great addition to our existing course material and professional development learning tracks.” ■

**FOR MORE INFORMATION** on NAHAD Academy and the new Fabrication Guides, go to [www.nahad.org/academy](http://www.nahad.org/academy).

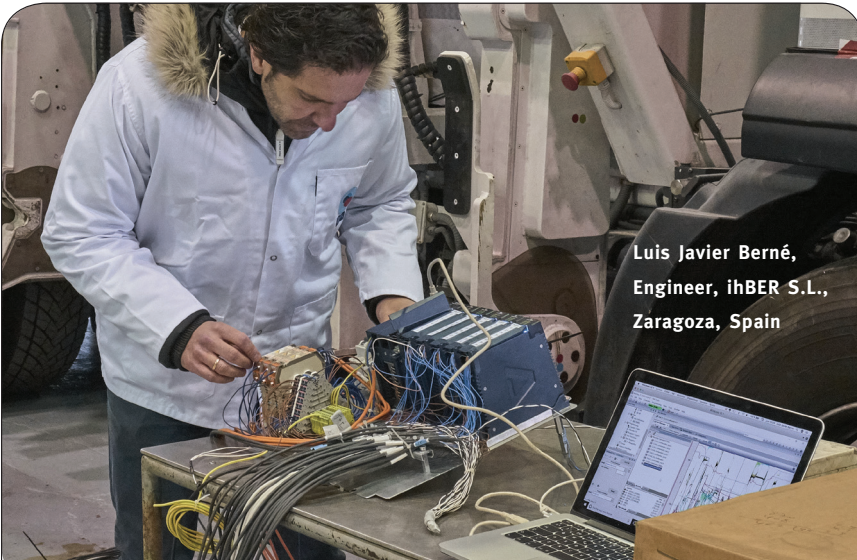

Luis Javier Berné,  
Engineer, ihBER S.L.,  
Zaragoza, Spain

### Complex hydraulics at your command.

Hydraulics innovator ihBER S.L., Zaragoza, Spain, uses a Delta high-performance RMC200 motion controller to gather 40 points of sensor data with high precision and at great speed for analysis to maximize energy efficiency.

Luis Javier Berné leads the hydraulics development project. “I chose the RMC200 because it is easy to use and the software provided with it has powerful plotting capabilities.”

Delta RMC motion controllers and graphical RMCTools software make testing applications using hydraulics repeatable, flexible and precise.

**Find your competitive edge. Call 1-360-254-8688 or visit [deltamotion.com](http://deltamotion.com)** Find the ihBER case study or one about your own industry or application. Watch a training video to see how Delta puts precise, flexible, complex hydraulic motion at your command.

#### Delta RMC Motion Controller Family



**DELTA**  
COMPUTER SYSTEMS  
**Motion Control**

## H&P, The Next Generation

**AT THIS STAGE OF HIS LIFE**, Malachi DeNizio's goal is to attend "robot school."

That is a lofty ambition, but he'll have to get through kindergarten first.

At age 4, Malachi already is a regular consumer of the articles from *Hydraulics & Pneumatics* magazine. His grandfather, Isaac Gutwillik—a subscriber for many years—now has to share his issue with Isaac every time they get together at Malachi's home in Winnipeg, Canada.

With the picture submitted to us this month, Gutwillik added the following narrative: "He is proudly holding up his favorite magazine. He loves it! He gets my daughter Michaela to read it to him, even though she has no idea what she is reading."

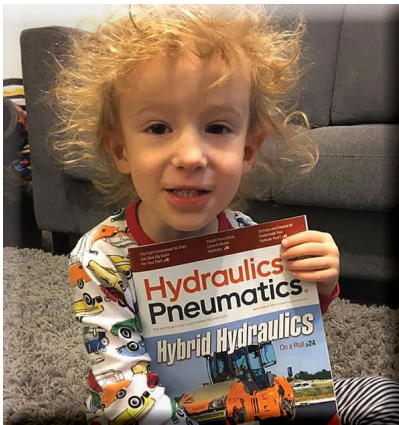

Malachi DeNizio, age 4

**W**e hear a lot of talk about where the next generation of fluid power engineers will come from, and we hope to encourage young people to consider this as a field.

We hear a lot of talk about where the next generation of fluid power engineers will come from, and we hope to encour-

age young people to consider this as a field. The influence of a grandfather and a mother's patient nurturing are two places to start, but we want to make sure we do our part as well. And we do appreciate all of our readers, no matter the length of

their industry experience.

That's why we've started Malachi DeNizio with his own subscription to *Hydraulics & Pneumatics*. We hope this is the next step on his journey. ■

(News continues on page 19)

## EVERY Part Matters!

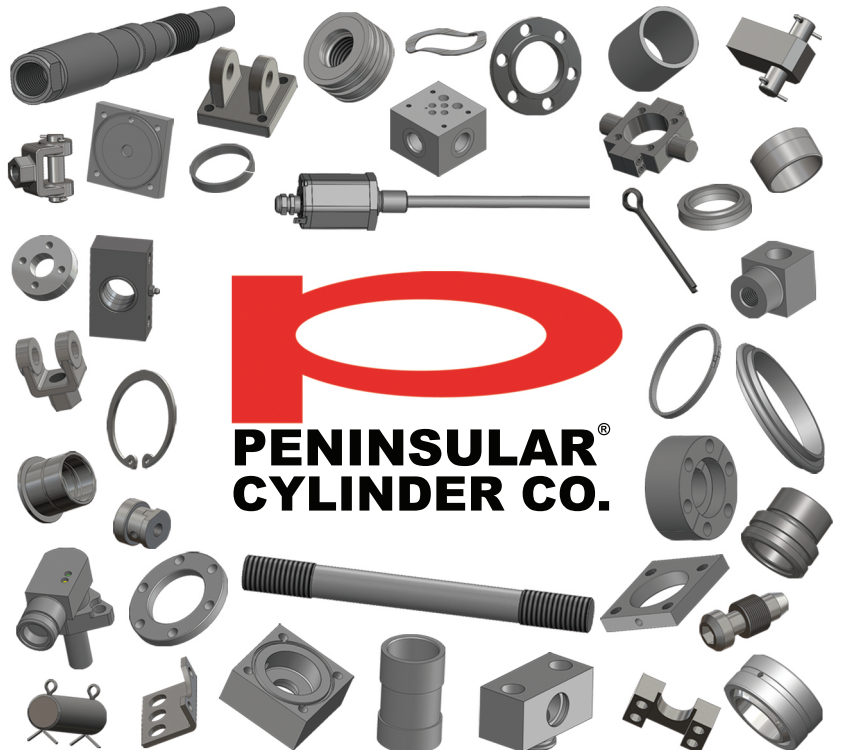

## Hydraulic • Air • Custom Cylinders



**Let's Talk Cylinders**  
**800-526-7968**  
[www.peninsularcylinders.com](http://www.peninsularcylinders.com)



# MOCAP<sup>®</sup>

Manufacturer of  
Quality Plastic and Rubber Products



Intertek



MANAGEMENT SYSTEMS  
CERTIFICATION INC.

**Caps • Plugs • Grips • Product Protection • Finishing • Masking**

- All Sizes & Styles in Stock
- Most Extensive Tooling
- Global Stocking
- Smallest Minimum Order Quantities
- Lowest Prices
- Easy Ordering

*Order Online For Fast Turnaround*

# Solutions that Fit<sup>®</sup> the Fluid Power Industry



Plastic & Vinyl Caps for gas,  
metric, UNF, JIC fittings  
(PVC, LDPE, HDPE, PP & NYLON).



Plastic and Vinyl Plugs  
for gas, metric, UNF, JIC fittings  
(PVC, LDPE, HDPE, PP & NYLON).



Flat and Round Grips



Masking Tapes, Discs,  
Caps and Plugs



Pipe and Flange Protection



...and *Much More!*

**MOCAP**  
**FREE**  
**SAMPLES**

1-800-633-6775

[www.mocap.com](http://www.mocap.com)

[sales@mocap.com](mailto:sales@mocap.com)

## Cover Story

THOMAS SCHWARZ, WOLFGANG SWETE, SILVIO SCHREYMAYER, MARTIN WALLNER,  
EMMANUEL PICHILMAIER and MICHAEL LIEBMINGER | SKF Seals

# How Buffer Rod Seals Influence Rod Seal Performance

In Part 1 of this article, tests reveal how these two seals interact to affect friction and seal life. But first, a look at buffer seals.

### AT A GLANCE:

- Buffer seals protect equipment against pressure spikes.
- The key factor with buffer seals is the thin film of oil it lets past.
- The main types of buffer seals are lip seals with back-up rings, lip seals without back-up rings and O-ring energized glide ring seals, each with their own performance characteristics.



Designers often specify buffer seals be placed in front of primary rod seals in heavy-duty hydraulic applications to extend the life of the seals. As the name indicates, buffer seals “absorb” pressure spikes typical on heavy-duty cylinders to protect the primary rod seals.

But how do these two types of seals interactions interact, which parameters affect those interactions, and how can they be used to extend the life of cylinder rod-sealing systems?

What was learned during these investigations will give engineers insights into seal types and interactions between seals so they can specify the most appropriate seals for their applications.

### BUFFER SEAL BASICS

A buffer seal must:

- Absorb system pressure spikes that could damage the primary rod seal.
- Let oil move past the seal lip to lubricate the primary rod seal and wiper.
- Vent intermediate pressure (*facing page*) between the buffer and primary rod seal when system pressure is below the intermediate pressure, thereby preventing a pressure trap.

The primary rod and buffer seals must:

- Prevent leaks by reducing lubrication film thickness and allow back-pumping into the system.



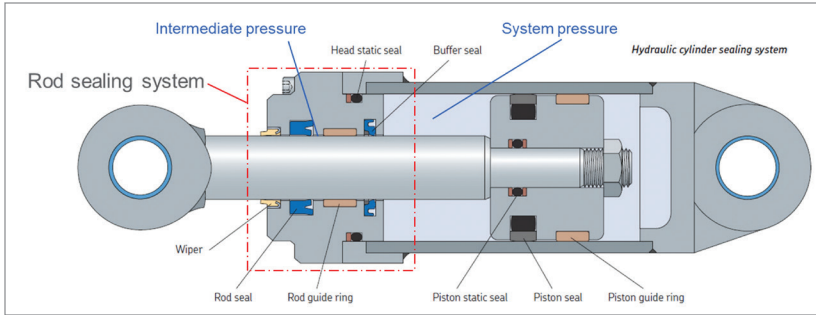

Here's a hydraulic cylinder with a typical sealing arrangement. The rod seal subsystem includes a buffer seal, a primary rod seal and a wiper.

- Adjust lubrication film thickness so there are the fewest and smallest possible leaks and low friction.
- Absorb intermediate pressure.

And the wiper must:

- Keep out all kinds of environmental contamination.
- Prevent leaks by pumping lubricant back into the system.
- Vent intermediate pressure between rod seals and wipers (This article focuses on the buffer and rod seals; wipers are not included.)

The key element of the buffer seal is the lubrication film thickness which passes the sealing edge. It is responsible for the performance of the entire rod sealing system. Different pressure and speed conditions during the in- and outstroke of the piston rod are typical for heavy-duty hydraulic cylinders and result in different oil film thickness. Therefore, the buffer seal needs to be designed to ensure a lubricated rod seal and absorb pressure peaks during operation.

Generally, buffer seals use one of two basic design principles:

**High sealability** buffer seals have good sealing abilities and can handle all of the system pressure and possible pressure peaks. Therefore, the primary rod seal will not be pressurized and can't be damaged by pressurization. The seal's high sealability means only a thin film of lubrication film can pass it, which could starve the primary rod seal of lubrication.

This can lead to stick-slip, higher friction and sealing-edge temperatures, and possibly damage to the sealing material, all of which shorten the rod seal's life.

**Friction optimized** buffer seals let thicker oil film pass the sealing edge to properly lubricate the primary rod seal. Depending on operating conditions, they can also let pressure build up between the primary rod and buffer seals (intermediate pressure).

These buffer seals should keep out system pressure, because if the intermediate pressure is equal to system pressure, it cannot buffer. It is also important to use a primary rod seal and a wiper for good sealing and back-pumping ability to guarantee a leak-tight system.

An additional advantage of this type of seal is that the primary rod seal gets better lubrication, leading to smooth running equipment. If the buffer and primary rod seal work together correctly (as described above), friction in the entire rod sealing system can be similar to that of a single rod seal

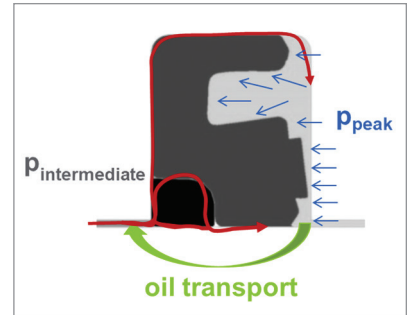

This schematic of main buffer seal shows its functions.

component. Reducing friction extends the life of the rod seal and the entire hydraulic cylinder.

Both working concepts have their place. Friction optimized buffer seals might be best in OEM components to extend a hydraulic cylinder's service life. But high-sealability buffer seals might be more suitable in the aftermarket, where repair work and maintenance on hydraulic cylinders is more common and a leak-tight rod seal is more important.

### BUFFER SEAL DESIGNS

There are many different buffer seal designs and various material combinations available on the market. Here are the three most common designs.

**Lip seals with back-up rings.** These seals are good in heavy duty applications, where pressure spikes climb past 600 bar. The best lip seals are made of polyurethane with a thermoplastic back-up ring. This design enjoys a longer service life because the back-up ring resists extrusion. On the other

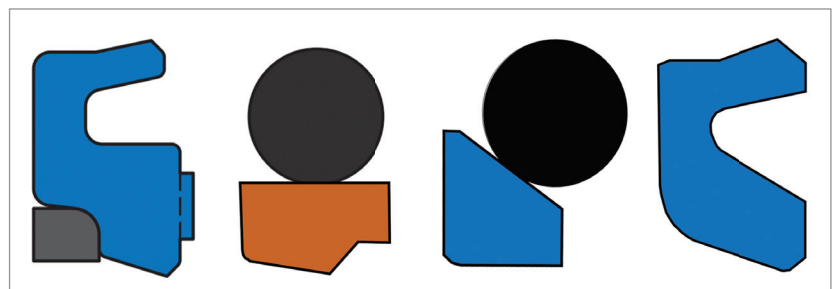

The ring energized seal on the left needs the O-ring to statically seal while the seal on the right uses the O-ring only as a position holder and energizer.

## Buffer Seals

hand, the back-up ring can influence the motion of the film of fluid on the piston rod, and seal installation requires more attention.

**O-ring energized glide ring seals.** These seals are widely used in light- to medium-duty applications. Generally, the O-ring acts as an energizer to push the glide ring towards the piston rod. A big advantage of this is that various materials can be used. For example, a low temperature rubber grade can be used for cold climate conditions. The various material combinations give designers a wide choice. These seals have less resistance to extrusion compared to those with back-up rings.

**Lip seals without back-up ring.** These are popular in Asia. This type of buffer seal has a radius on the seal lip to let oil past it. They are cost-competitive but are also as limited in pressure and extrusion resistance, and don't perform as well at absorbing pressure spikes.

**The buffer seal's main task is keeping the lubrication film thickness that passes through the seal's edge at the right thickness. According to the Reynolds equation, the flow of a thin film oil/lubricant between two surfaces is influenced by its velocity, the gradient of the contact pressure distribution and the oil's viscosity.**

The buffer seal's main task is keeping the lubrication film thickness that passes through the seal's edge at the right thickness. According to the Reynolds equation, the flow of a thin film oil/lubricant between two surfaces is influenced by its velocity, the gradient of the contact pressure distribution and the oil's viscosity.

An important aspect of the investigations was to understand lubrication behavior under different test parameters. The lubrication level of lubrication determines friction and is essential for seal life. On the other hand, the lubrication level also determines the number and size of leaks, which should be minimized for the sake of performance and environmental concerns.

The lubrication level is influenced by instroke and outstroke piston-rod velocity, seal design and the type of hydraulic oil used.

The influence of different in- and outstroke velocities has already been

EXTREME ENVIRONMENTS CONTROL

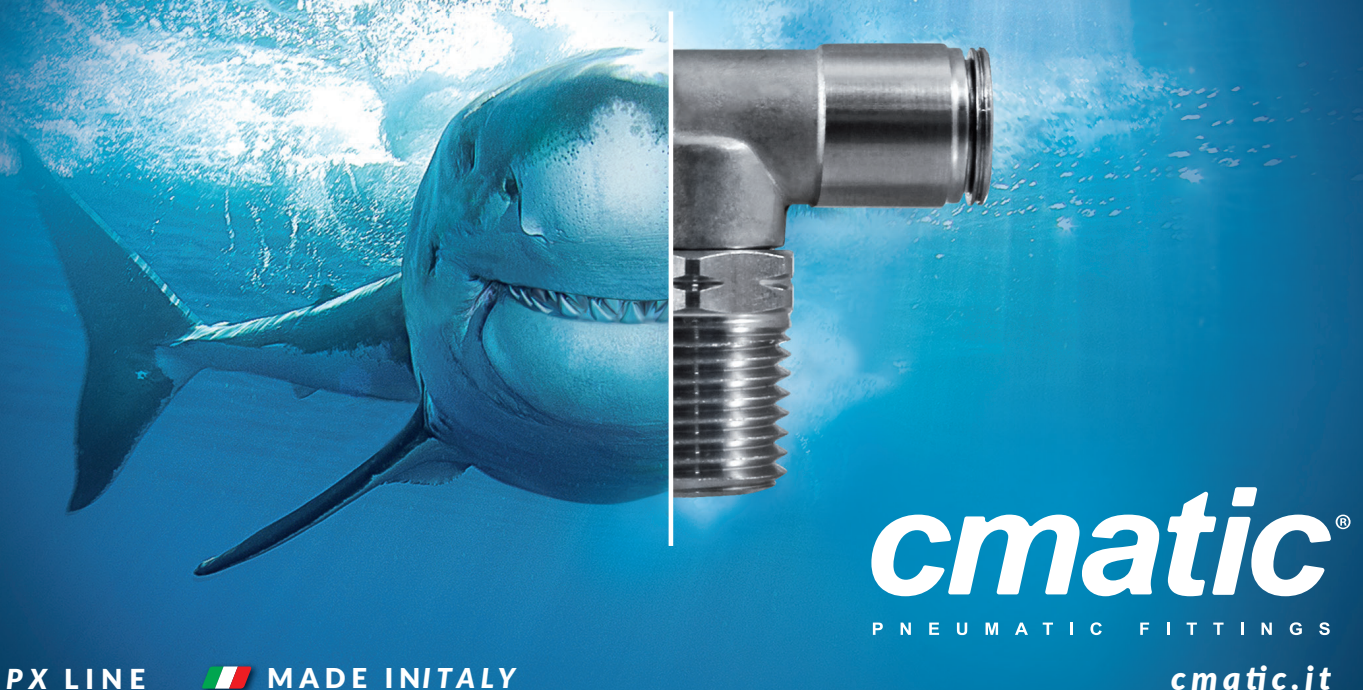

**cmatic**<sup>®</sup>  
PNEUMATIC FITTINGS  
[cmatic.it](http://cmatic.it)

PX LINE  MADE IN ITALY

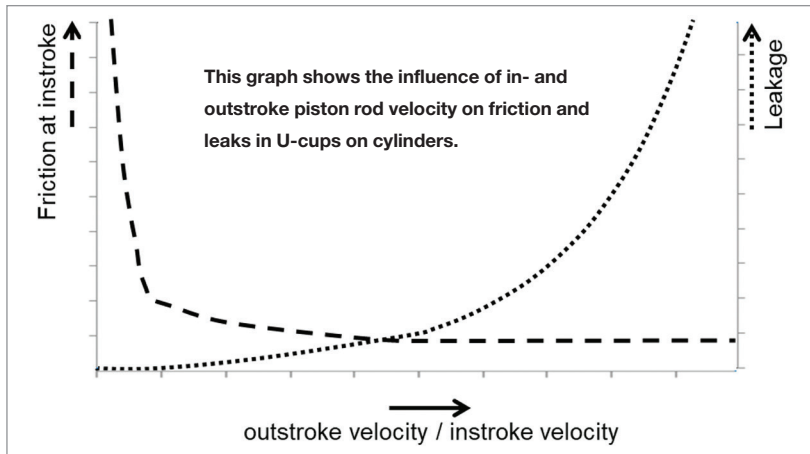

analyzed for a common U-Cup rod seal (see above graph). The results show that if outstroke velocity is much higher than instroke velocity, the likelihood of leaks increases. On the other hand, if instroke velocity is much higher than outstroke velocity, it is more likely the low-level of lubrication will increase friction on the instroke.

The second driver for the lubrication film thickness is contact pressure between the seal and piston rod. The higher the pressure gradient, the thinner the film. The gradient is influenced by seal design, the pressurization level, and the resulting deformation and dynamics between piston rod and seal.

The third driver for the lubrication film thickness is the lubricant's viscosity. The lower the viscosity, the thinner the lubrication film.

In the second installment of this series, tests are set up and run, and the results analyzed, revealing what factors of buffer seals matter most to rod seal performance and longevity. **hp**

PART 2 OF THIS ARTICLE, *Test Results Compare Buffer Seals for Hydraulic Cylinders*, will appear in the next issue.

THOMAS SCHWARZ is manager of testing, materials technologies & research; WOLFGANG SWETE is manager of product technology and development; SILVIO SCHREYMAYER is manager of testing; MARTIN WALLNER is manager of product development; EMMANUEL PICHLMAIER is a product development engineer; and MICHAEL LIEBMINGER is a testing engineer for SKF Sales ([www.skf.com/us](http://www.skf.com/us)).



### COST-EFFECTIVE, HIGH-QUALITY, PRECISION-MACHINED FLUID POWER COMPONENTS & ASSEMBLIES:

- USA Headquarters & Warehouse – North American Inventory, Sales, Service, & Support
- Cost-Effective Manufacturing Locations on the Pacific Rim
- Quality Products – ISO 9001:2015 and IATF 16949:2016 Certified
- Over 30 Years of Experience in Fluid Power Manufacturing
- Assembly and Test Services Available

### PRODUCTS RANGE:



- Valve Bodies & Spools
- Cartridges & Poppets
- Pump Gears & Shafts
- Housings
- Manifold Blocks
- Fluid Power Systems
- Gerotors
- Pump, Valve, and Motor Assemblies

***We Can Help Make Your Next Project A Success!***

Tuson Corporation – 475 Bunker Court Vernon Hills, IL 60061 – USA  
 Phone: +1-847-816-8800 – FAX: +1-847-816-8801 – Email: [info@tuson.com](mailto:info@tuson.com) – Website: [www.tuson.com](http://www.tuson.com)

***Exceeding Customer Needs and Expectations Since 1987***

# How Bode Plots Describe Servo Valves Specifications

Engineers should know and understand Bode plots to make the best of their valve decisions.

Valves good enough to be used in motion control applications have Bode plots in their specifications. The problem for engineers is interpreting what the Bode plots are trying to convey.

Basic Bode plots graph two lines of data: the magnitude or gain and phase. Both lines are plotted as a function of frequency. The frequency scale is logarithmic and may be in radians per second or Hertz (Hz). Most Bode plots for valves use a logarithmic frequency in Hertz.

The magnitude or gain scale is measured in decibels (db) and is like the frequency response of audio equipment. Decibels are calculated using a logarithmic formula but are plotted on a linear scale.

The basic formula is:

$$\text{gain}_{\text{db}}(\text{Hz}) = 20 \log_{10} \left( \frac{\text{amp}(\text{Hz})}{\text{amp}_{\text{Ref}}} \right)$$

The amplitude and phase of the valve spool is compared to the amplitude and phase of the valve's input. A signal generator sends the input sine wave to the valve in range of different frequencies. As the frequencies increase, the valve spool's sinewave amplitude decreases and phase delay (measured in degrees) increases.

The spool's amplitude gets compared to a reference amplitude taken at 0 Hz. The phase delay between input signal and the spool response is also measured as a function of frequency.

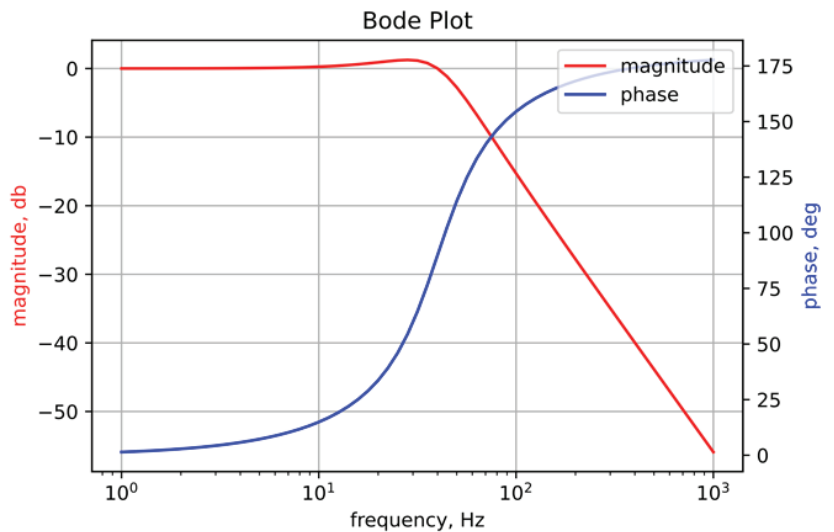

How is spool position measured when it is inside the valve? Servo solenoid valves provide spool position voltage feedback that makes comparison easy.

What are the oil pressures during the test? At higher pressures, flow forces affect the spool's motion.

The answers to these questions are not in the valve manufacturers online data files. This makes comparing valves based on manufacturer's specifications an inexact estimation.

Valve manufacturers like to give valves ratings of 30 Hz. Typically, they rate valves at the point the gain drops to -3 db, or sometimes at a phase delay of 90 deg.

The Bode plot above shows the magnitude and phase for a simulated valve with a natural frequency of 40 Hz and a

damping factor of 0.5. Magnitude drops to -3 db, and phase delay increases to about 90 at near 50 Hz.

Notice that the magnitude increases a little above 0 (unity gain) at about 15 to 30 Hz. This is due to the lower damping factor. The 'bump' in the gain decrease as the damping factor increases.

Bode plots for valves show phase differently from how textbooks do it. Valve Bode plots show phase delay at 0 in the lower left and increasing to the right. Most textbooks, however, show phase delay starting at 0 at the top left and decreasing to the right.

There are two difficulties with the way valve manufacturers rate valves. The -3-db. rating should not be used for estimating the valve's true response. The -3 db rating at 50 Hz means a valve



**ACCURACY**



**CONNECTIVITY**



**ANALYSIS**



**INFORMATION**



**EFFICIENCY**



**EASE OF USE**

**DOWNLOAD OUR APP**



**MP FILTRI CONNECT**



**WiFi Enabled**



**Industry 4.0 READY**



## ICM 4.0

### DISCOVER THE POWER OF CONNECTIVITY

A 24/7 real-time monitoring and critical early warning system, the ICM 4.0 delivers the ultimate in hydraulic health checks - with all data accessible via a sophisticated software suite and an innovative new mobile phone app.



**PASSION TO PERFORM**

(215) 529.1300  
[www.mpfiltriusa.com](http://www.mpfiltriusa.com)  
[sales@mpfiltriusa.com](mailto:sales@mpfiltriusa.com)

**WE TAKE SOCIAL DISTANCING SERIOUSLY**

**Tompkins**  
INDUSTRIES, INC.

WE'RE WORKING TODAY FOR A BETTER TOMORROW

800-255-1008 | [tompkinsind.com](http://tompkinsind.com)

**Bode Plots**

spool that should move  $\pm 1$  mm only moves  $\pm 0.707$  mm. Assuming the valve is linear, that results in almost a 30% speed decrease from the desired value. For motion control purposes, it is better to use the frequency where the magnitude is 0 db. In the example above, that frequency is about 30 Hz.

Another problem is using the 90-deg. delay rating for motion control. That's because the actuator's velocity is controlled by the valve, but we usually want to control position. Integrating velocity to position adds 90 deg. of phase delay. If the valve spool also adds 90 deg. of phase delay, the total phase delay goes beyond 180 deg. because other small phase delays must also be included.

When phase delay goes beyond 180 deg., the system oscillates. Practically, it is best to look at the frequency where the valve's phase delay reaches 45 deg. and use that value as the valve's usable frequency response. In the graph above, this happens at about 28 Hz.

The fact that spools are often slew-rate limited makes plotting Bode plots accurate. (Slew-rate limited valves have a maximum speed.)

Many valves have Bode plots with more than one line for gain and phase. There may be two or three plots measuring the responses at different sinewave amplitudes. Usually there is a plot for sine wave amplitudes with input signals for 5% travel. These responses are good, but one does not buy a 100-liter-per-minute valve to use only 5-liters-per-minute of its capability. However, it's helpful to know the 5% response when doing pressure or force control because the valve's pressure band is usually just a few percent around null. When making normal point-to-point moves, it is the response at 90-95% input that is important.

When designing position servo-control systems, engineers need to look at and understand a valve's Bode plot to get a better estimate of the valve's real capabilities and avoid unwanted surprises. 

**PROUDLY SERVING THE INDUSTRY FOR OVER 60 YEARS**

**HYDRAULIC FLANGES AND COMPONENTS**

* SAE J518 4-Bolt	* ISO, JIS, DIN	Request <b>MAIN's NEW Catalog</b>
* Flange Adapters	* Metric Ports	
* Stainless	* Specials	

**MAIN'S ADVANTAGES**

**DEPENDABLE** - 60 years of hydraulic experience

**INFORMED** - Main's engineers are active on the SAE, NFPA, and ISO tech committees

**QUICK** - Thousands of Styles and Flange Types STOCKED



Grand Blanc, MI 48439  
800.521.7918  
info@MAINmfg.com  
www.MAINmfg.com/hp

**A U.S. MANUFACTURER**



(News continued from page 11)

## MANUFACTURING STEADIES as Plants Successfully Adapt

**MANUFACTURING'S REBOUND** from its COVID-19 crash continued in September, as the Institute for Supply Management's monthly PMI Index remained solidly in growth territory at 55.4%.

While the September figure was down 0.6 percentage points from August's 56.0% reading, ISM officials said the overall sector remained on solid footing.

"Manufacturing performed well in the month with demand, consumption and inputs registering growth indicative of a normal expansion cycle," said Timothy Fiore, chairman of the ISM's Manufacturing Business Survey Committee. "While certain industry sectors are experiencing difficulties that will continue in the near term, the manufacturing community as a whole has learned to conduct business effectively and deal with the variables imposed by the COVID-19 pandemic."

After the PMI plummeted in April following the shutdown of many business during the early days of the pandemic, manufacturing has gradually recovered. The PMI has been solidly above the 50% growth level for the past four months. In the September report, growth in new orders and production leveled off, but remained in solid shape.

"After the coronavirus pandemic brought manufacturing activity to historic lows, the sector continued its recovery in September,"

Fiore said in a press release. "Survey Committee members reported that their companies and suppliers continue to operate in reconfigured factories and are becoming more proficient at maintaining output. Panel sentiment was optimistic (2.3 positive comments for every cautious comment), an improvement compared to August."

While supply chain pressures continue, committee members said that was the lone area of concern in a generally positive outlook. Among the committee member comments:

- "Still struggling with long lead times for components coming from China [contract manufacturers]." (Computer & Electronic Products)
- "Business is booming, and the supply chain has been caught off guard. We are working closely with our suppliers to ensure supply and try to control costs. The resin industry, along with plastics, is driving cost increases and scarce availability." (Transportation Equipment)
- "Raw material shortages, especially of hardwood logs, are starting to impact overall supply. Domestic market demand is fragmented but remains sound. Export demand, especially to China, is robust." (Wood Products)
- "Our business has not begun to recover." (Petroleum & Coal Products) ■

# In And Out

## TM1 Series Position Sensors for In-Cylinder and Outside Cylinder Use.

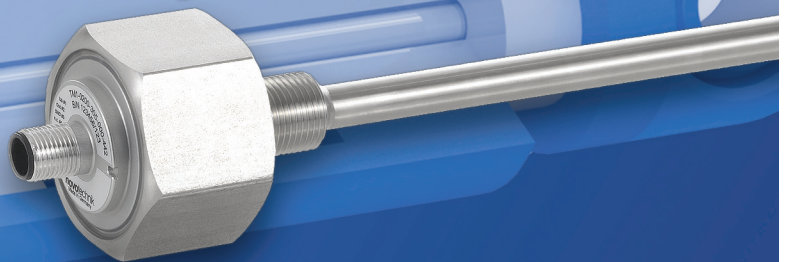

TM1 Series magnetostriuctive sensors are available in **screw flange or plug-in flange models** and utilize a ring-shaped magnetic marker for touchless operation.

### Key Specifications include:

- Absolute linearity  $\leq \pm 0.04\%$  FS (min. 0.3 mm)
- Absolute output: meets specs without calibration
- Operating pressure range of 0 to 350 bar (5,000 psi), 450 bar peaks (6,500 psi)
- Stroke lengths: 50 to 2,000 mm (1.9 to 78.7 in)
- Repeatability  $\leq \pm 0.1$  mm
- Sealed up to IP 69K
- EMC compatibility tested

To learn more contact  
Novotechnik or visit  
[novotechnik.com/tm1](http://novotechnik.com/tm1)

**novotechnik**

Siedle Group

Novotechnik U.S., Inc.  
Tel: 508-485-2244

Email: [info@novotechnik.com](mailto:info@novotechnik.com)



Water gates lifted by hydraulic cylinders can be safely held open any amount by hydraulic locking devices.

# HYDRAULIC LOCKS

## Protect Against Unplanned Moves and Dropped Loads

Even better, they add a level of safety to critical applications.

**H** ydraulic and pneumatic circuits contain load-holding and control valves; each holds an applied load in place and controls its rate of motion. When they operate as expected, they improve the circuit's safety and control. These valves are the basic and the first line of load-holding safety—they are staples of circuit design.

But many critical safety and performance circuit requirements call for levels of safety these valves cannot provide on their own. Used alone, the valves and the rest of the hydraulic or pneumatic circuit are limited. Any failure or sticking in the valve, parallel check valves, hoses or fittings—or even seals leaking

in an actuator—can cause unplanned and unsafe load movements if valves are the sole means of safety. Typically, these valves cannot be eliminated. Instead they must be supplemented to get the level of safety that is needed.

### LOCKING OPTIONS

There are different options for supplemental mechanical locking and important parameters when choosing which to use: power needs; space available; operating pressure; operating environment; the need for locking in any location along the stroke, or only in fixed positions; and whether automatic or manual locking is best. These parameters determine the available options.

The most advanced locks hold the actuator rod anywhere along the stroke. They are “power removed” locks that instantly lock the rod when input pressure (power) is removed or lost. These locks are typically spring loaded or contain a second smaller hydraulic or pneumatic cylinder that is placed as a collar, or an installable “head,” on top of the main actuator-rod end cap. The lock fits around the rod and clamps against it to prevent movement.

These locks are inexpensive and common and are effective within their design limitations. They are intended to prevent failure, and with some designs, the load must be removed and the actuator moved in a specific direction to release the lock.



## HYDRAULIC LOCKS IN ACTION

**WATER FLOW GATES** operated by hydraulic cylinders are critical to prevent floods and control water flow to electric turbines, so as to keep them operating without being damaged. Hydraulic locks can hold the gate at any position by stopping at any position along the actuator's stroke when power is switched off or lost. It can then move in either direction—gate open or closed—when power is restored.

This ensures safety is retained and property damage prevented.

Below are two water-gate control schematics with a hydraulic lock, a crest gate mounted on the top of a dam sill and a wheeled vertical liftgate.

Areas with red dashed lines contain components the system depends on to lock a load in place or prevent drift when locked. In these illustrations, the lock

takes the hydraulic circuit and power out of the equation for load safety and lock-out. It also would hold the load even if the hydraulic fluid completely bled out and any or all the seals on the cylinder were damaged or lost. Only the cylinder body, rod and lock are needed to maintain the lock. Removing power engages the locking system; restoring power unlocks it and renews operation. ■

**A Crest Gate Mounted Atop a Dam Sill**

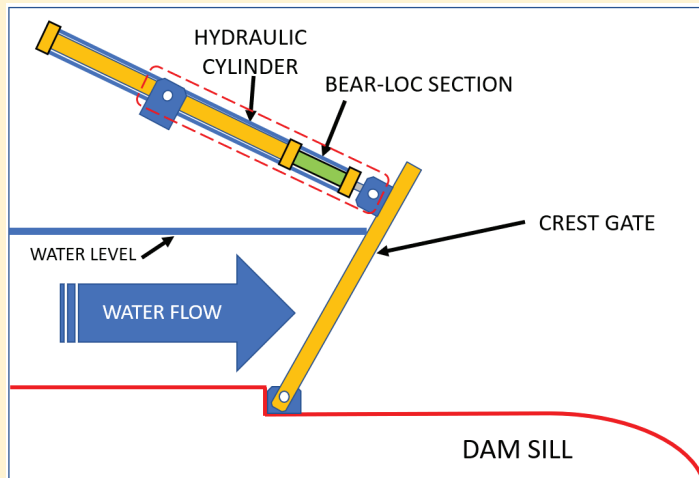

**A Wheeled Vertical Liftgate**

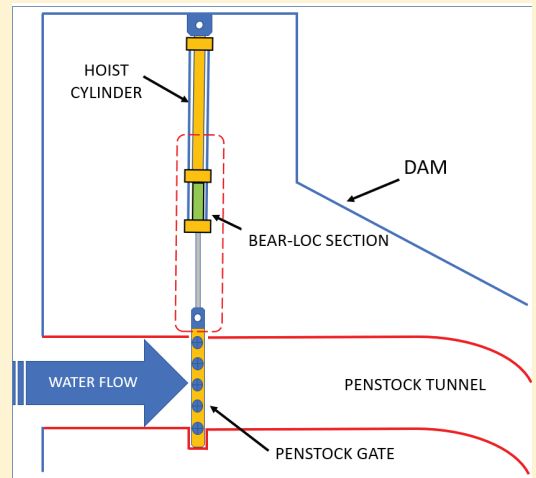

These off-the-shelf locks come in common rod sizes and can be hydraulic or pneumatic. They should be reliable and reusable and operate without too much maintenance or replacement requirements. They tend to be limited to cylinder pressures of 2,500 psi or less, so they cannot be used for high-load applications or with higher operating pressures.

With power removed, interference locks built into hydraulic cylinders deliver the highest level of safety performance. They meet the highest load demand and operating pressures, instantly locking at any position with no drift. They eliminate the need for other components in the power circuit that might cause a failure, including the cylinder seals and the fluid itself. They provide safety using just the integrat-

ed locking feature, the cylinder body and the rod. This means the cylinders have the fewest possible component fail points and failure modes that could cause uncontrolled and unplanned load movements or failures.

These designs are the strongest locking options in strength and will lock anywhere on the rod. They also provide zero backlash and high stiffness when required. They can have instant lock or unlock and there is no wear on components. As a positive lock, they lock when hydraulic pressure is removed, removing the risk of accidental pressure loss from any cause.

One locking system that meets most design criteria is the Bear-Loc from York Precision Machining & Hydraulic. It includes a supplementary section that attaches to the cylinder cap end.

The system comes with a sleeve that creates an interference clamping/frictional lock; this holds the rod in any phase of the stroke when hydraulic pressure is removed. The sleeve has a fluid pressure lock and unlock port at the ends of the sleeve that are part of the hydraulic circuit.

The Bear-Loc design uses the elastic expansion of metal sleeve under pressure. When hydraulic pressure is applied, the sleeve expands radially, loosening the interference fit on the rod and making enough room for it to move with virtually no resistance. Removing the hydraulic pressure in any way makes the sleeve instantly engage its interference fit against the rod and clamp down on it. The sleeve is lined with a material that prevents the rod plating from degrading over the lifecycle of the rod.

## Hydraulic Locks

The Bear-Loc instantly locks or unlocks simply by activating or deactivating system power, and there is no need to remove the load or depressurize the cylinder to unlock it. The device's locking power depends on several factors, chiefly operating pressure, rod diameter and available sleeve length.

Bear-Locs are a step up in safety because they are built into the cylinder. They operate in most conditions, including underwater (fresh or salt) and other high-stress environments that would degrade or destroy any other system components. Nevertheless, load control is maintained with no safety risk. Movements take place while "unlocked," so there is little wear. Bear-Loc has been known to last years, and even decades, when used according to the manufacturer's specifications.

These locks have tight tolerance and are typically customized to operate at loads from 880 lb to 4 million pounds under pressures ranging from 2,000 to 5,000 psi, and can handle rod diameters of 1 to 25 in.

The value in this technology is absolute fail-proof design without supplementary subsystems or circuitry to depend on for safety. These designs are superior in any design using hydraulic cylinders that must have fail-proof operation.

Does your application require:	Yes/No
Higher system pressures (2,000-5,000 psi)?	
No cylinder drift?	
Fail-safe operation?	
Design simplicity: few parts, friction-free movement?	
Automatic locking/control?	
High position accuracy?	
Locking/holding anywhere along the stroke?	
High-load rating?	
Long lifetime durability and repeatability of use?	
High acceleration?	
Reliability?	
Low maintenance and Repairability?	
Motion possible in any direction?	
Zero backlash?	
High system stiffness?	
Marine-submerged operation and durability?	
Able to withstand extremes in temperature, climate and environment?	

As engineers design or modify hydraulic or pneumatic systems, they can use this checklist to decide what features an application requires. Then they can select the right ones that can provide safe, long-lasting, reliable and productive control.

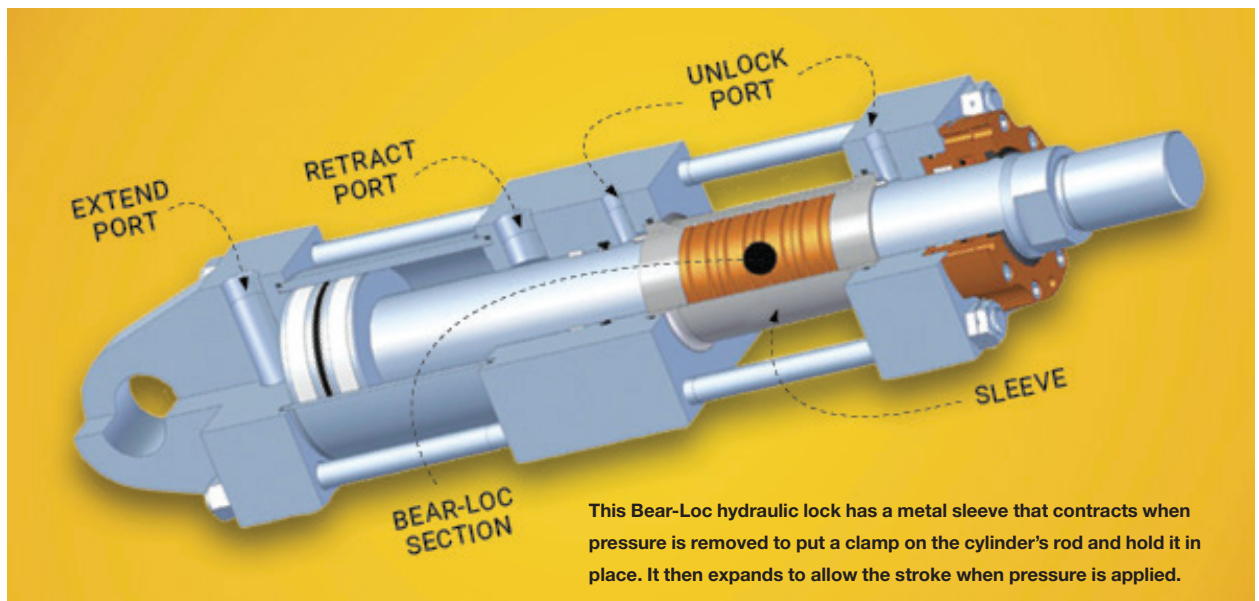

## EQUIPMENT THAT NEEDS HYDRAULIC SAFETY

Construction and mining equipment such as cranes
Load handling equipment such as fork-lifts and stock pickers
Aerial work platforms such as boom trucks
Test equipment
Weapon systems, including missile launchers
Manufacturing equipment such as industrial presses
Oil drilling rigs
Amusement park rides
Water diversion and control systems

It is often asked if the Bear-Loc can serve as a rod brake to slow or bring them to a stop as a regular part of operations. They can be used for emergency stops, but not routinely. It is important to note that this article is not discussing cylinder or rod brakes. Locking is different from stopping, which should probably be handled by a load-holding valve.

It is often asked if the Bear-Loc can serve as a rod brake to slow or bring them to a stop as a regular part of operations. They can be used for emergency stops, but not routinely. It is important to note that this article is not discussing cylinder or rod brakes.

Making design decisions involves trade-offs on performance, safety, cost, schedule, reliability and the machine's life cycle cost of the system. There are numerous considerations as safety is designed into hydraulic and pneumatic systems to meet these project needs. While performance has a price tag, it can also lead to peace of mind, consistent operations and reduced waste. 

DAVID BICKFORD is a principal engineer with York Precision Machining & Hydraulics. For more information, visit [www.yorkpmh.com](http://www.yorkpmh.com).



schematic on the cloud ISO and DWG compliant  
\$19/month\* [NetSkeme.com](http://NetSkeme.com)



collaborate with vendors and customers  
Try Now [ManifoldEdge.com](http://ManifoldEdge.com)



circuit design software with AutoCAD® OEM  
\$119/month\*



manifold design software for Inventor® and SOLIDWORKS®  
\$458/month\*

\* annual purchase, dedicated user



[VESTusa.com](http://VESTusa.com) [sales@VESTusa.com](mailto:sales@VESTusa.com)

# Piezo-Electric Valves for Hydraulic and Pneumatic Systems

Piezo actuators provide a combination low power, low weight and accuracy.

**P**iezo elements are electro-mechanical transducers that convert mechanical forces (pressure, tensile stress or acceleration) into voltages. The inverse piezoelectric effect, precisely the opposite, forces piezo elements to change shape when a voltage is applied to them. This lets them generate mechanical motion and be used as oscillators.

The piezoelectric effect (from the Greek word for “pressing”) was discovered in 1880 by the brothers Jacques and

Pierre Curie, the latter being the husband of Marie Curie. They found some materials, usually ceramics with conductive surfaces, convert electrical energy into mechanical energy and vice-versa.

Using strong electric fields, engineers can give some ceramics piezoelectric properties that make them change shape when a voltage is applied. These shape changes can be harnessed to power a drive and be created using almost zero power. This is one advantage of piezoelectric valves and drives.

In electrical terms, a piezo element is a capacitor consisting of two electrically conductive plates and the ceramic piezo material between them acting as a dielectric. Current only flows while the capacitor is charging, and flow drops to zero when charging is complete. Electrical power is calculated as voltage × current, so the power is zero if no more current flows. In applications that need to be extremely energy-efficient, it is even possible to recover the charging energy when the drive is reset and then use it again for the next charging operation.

## TYPES AND VERSIONS OF PIEZO TRANSDUCERS

Piezo elements can be crafted into several types of actuators, depending on what the needs are: disc transducers, bender actuators or piezo stacks.

Bender actuators are rectangular with a piece of piezo ceramic material that has been rendered conductive on both surfaces. This piece is also joined all along one side to a conductive substrate. One end of the actuator is usually fixed, so motion gets converted to a bending movement.

Bender actuators can be designed to have a range of possible forces and motions, and they are well-suited for use in pneumatic valves. Typical characteristics include deflection of several tenths of a millimeter and forces up to 1 N.

One variation on the bender actuator is called the trimorph. It has a second ceramic layer sandwiching the substrate. This increases its performance and lets it operate across a wider temperature ranges, thanks to its symmetry.

Bender actuators are used in circular knitting machines, reading devices for

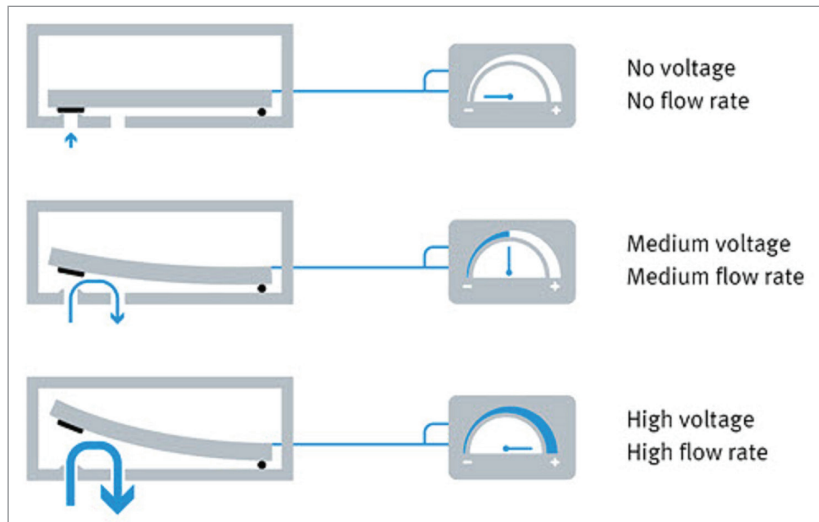

Piezo elements are electromechanical transducers that convert mechanical forces (pressure, tensile stress or acceleration) into voltages.

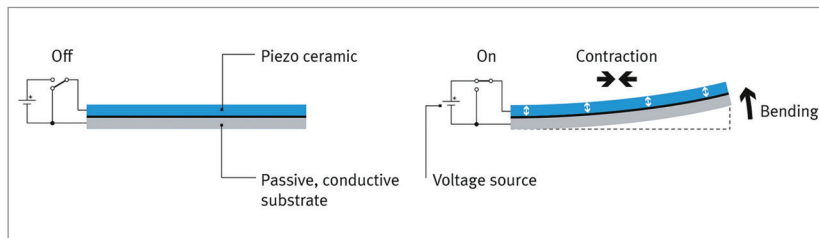

Bender actuators can be designed to have a range of possible forces and motions, and they are well-suited for use in pneumatic valves.

those with bad eyesight (Braille modules) and pneumatic valves—especially proportional valves for pressure and flow control.

A disc transducer consists of a thin ceramic disc bonded to a metal substrate. To generate an electric field, the flat area on the disc's top surface must be metalized. If a voltage is applied to the top surface and the ceramic disc, the ceramic expands and the disc becomes thicker with a smaller diameter. Overall, the disc bends spherically, letting them be used in high-frequency loudspeakers, sensors, micro pumps, fans and ultrasound generators, such as are often used in automobile distance sensors.

Stack transducers (piezo stacks) are towers of stacked piezo discs connected mechanically in series but electrically in parallel. In contrast to disc transducers, operation is not triggered by bending the composite material but by expansion in the direction of the field. This allows only short strokes—a maximum of 0.2% of the overall height—but with actuating forces of up to several kilonewtons. Stack transducers can be found in liquid valves, such as those used in diesel fuel-injectors and micro positioning.

#### OPERATION OF PIEZO VALVES

Piezo elements shaped as benders serve widely in pneumatic valves. A piezo valve's performance depends on the strength of its electric field: The greater the field strength, the better the actuator and valve perform.

Switch-on energy,  $E$ , can be calculated as an approximation using the formula  $E = CU^2/2$ , where  $C$  is the transducer's capacitance and  $U$  is the control voltage. Values usually lie between 0.5 and 5 mW, and the transducer's capacitance is generally around 30 nF with control voltages up to 300 V DC. Switch-on energies of piezo valves are always specified in milliwatt seconds. It is not possible, as with solenoid valves, to specify power in watts.

When a piezo valve has been switched on and the power supply interrupted,

the valve remains on because charge carriers cannot flow past the interruption. To reset the valve, the transducer charge must be removed. This can be done by using buffer storage in another system (energy recovery) or converting the energy to heat (short circuit). This is why it takes a changeover switch instead

of an on-off switch to operate the valve.

In the world of electrically controlled pneumatic valves, solenoid valves are the absolute standard with a market share of almost 100%. Nevertheless, piezo valves offer many advantages over the solenoids and open up entirely new areas of application.

## Your Designs, On Time

Shorten your lead times—even for custom cylinders

**FABCO-AIR**  
A member of Festo Group



### F Series

- Configurable general purpose cylinder
- Twelve bore sizes (5/16 to 3") and standard strokes to 32"
- Options include adjustable air cushions, Viton® seals, rod wipers and more
- Support for food packaging or washdown environments

### Pancake II

- Robust compact actuator
- Eight bore sizes (1/2 to 4") and up to 9" stroke standard
- Composite body enables impact resistant, self-lubricating operation
- Composite rod bearing for reduced wear and increased load capacity

### OEM NFPA

- Cost-optimized NFPA interchangeable pneumatic cylinder
- Five bore sizes (1-1/2 to 4") and strokes up to 48" standard
- Adjustable air cushions and magnet for position sensing standard
- Variety of NFPA mounting options

## Piezo-Electric Valves

- Low energy consumption and no heat generation. By using the capacitive principle, piezo valves require virtually no energy to maintain an active state. They also do not generate heat, provided high-frequency controls are not used. And they are not used because higher control frequencies need higher switch-on energies.
- Piezo technology is ideal for battery-powered devices. Compared to solenoid valves, piezo versions increase the service life of a battery pack by a factor of seven or greater.
- Intrinsic safety is a term describing the level of protection required on hardware that will operate in potentially explosive atmospheres. An electrical system is intrinsically safe if most energy it can store can't cause ignition of the atmosphere if there's a fault. Piezo valves can meet this requirement.
- Switching speeds are playing larger roles in today's high-speed applications, such as sorting systems. Piezo valves are ideal as they can be incredibly fast, easily reaching the submicrosecond range.
- Anti-magnetic. Piezo valves operate despite high magnetic fields such as near magnetic resonance imaging (MRI) machines.
- Minimal weight due to housings made of mostly plastic, with little to no iron or copper. Lighter equipment is always more portable.
- Low costs in high volumes. Piezo valves can be mass-produced if large quantities are required. For example, piezo-ignited lighters are available at low cost.
- Long service life. Piezo valves drives can handle an unusually high number of operating cycles if well designed. They consist of a single, solid-state working component with

no other wearing parts subject to friction.

**Lightweight piezo valves are well suited to portable oxygen equipment.**



# Stainless Steel

**pneumatic fittings, cylinders  
valves & couplers**

**FMK seals • INCH & METRIC sizes available**  
[www.aignepusa.com](http://www.aignepusa.com) • 615-771-6650

# MOCAP®

**Solutions that Fit® the Fluid Power Industry**  
 Caps • Plugs • Grips • Protection • Finishing • Masking

Many Sizes and Styles in Stock  
 for Metric, SAE, BSP, JIC, NPT Threads & Fittings

*Order Online For Fast Turnaround*

**1-800-633-6775**  
[www.mocap.com](http://www.mocap.com)    [sales@mocap.com](mailto:sales@mocap.com)

**FREE SAMPLES**    Intertek    ANAB

**INDUSTRY APPS**

**Flow control.** Some applications use flow regulators with constant mass flow rates for long periods of time. Typical examples include production of artificial atmospheres such as those required by semiconductor fabrication at the front end for coating and at the back end for bonding. This type of load is easy for a piezo valve because it involves a steady state with virtually no consumption of energy. But it would be an extremely heavy load for a pulse-width modulated switching valve—both in terms of energy and mechanically.

**Handling fragile workpieces.** One method for moving sensitive workpieces is the “speed controller” for double-acting pneumatic cylinders. This lets a pneumatic cylinder execute speed-controlled, jerk-free motions. It takes four piezo valves hooked to a controller to form a system that can be connected

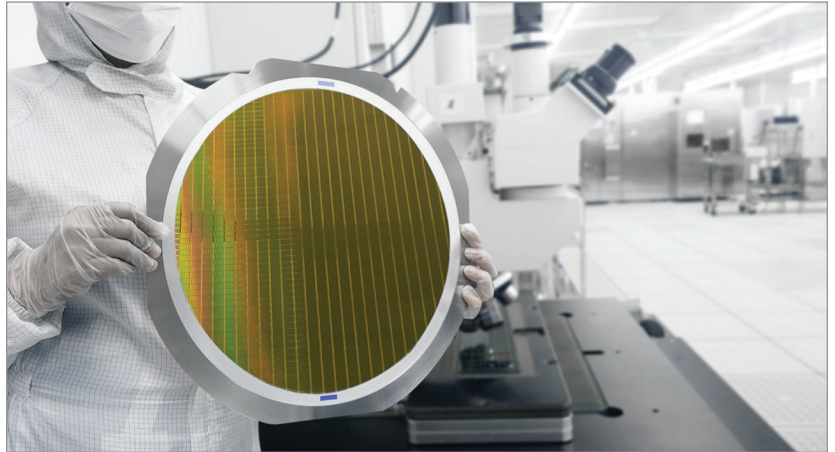

The Festo piezo-based N2 purge system for a silicon wafer maker significantly reduces risks of oxidation caused by particle contamination.

to a double-acting cylinder. Speed is controlled by maintaining a constant cylinder exhaust flow rate. This low-cost system does not need an expensive displacement encoder and can execute smooth start-ups and braking.

**Applying adhesives.** To prevent drips after pneumatically applying adhesive, a vacuum is applied after a predetermined amount of glue has been applied. This takes metering when assembling small parts.



Tech Talk  
Webinars by  
RHEINTACHO

# HIGH PRESSURE



**Did you know...**  
The sperm whale can dive to over 2,000 meters deep while withstanding a water pressure of over 200 bar. Our high-pressure sensors have a high compression strength up to 400 bar!



www.rheintacho.com



## Fluid Conducting Swivel Joints

**Full 4:1 Safety Factor—Field Repairable—RoHS Compliant**  
Hydraulics, Inc., swivels provide system developers the opportunity to select swivels having geometric relations of fluid ports that compliment the movement between a systems fluid ports. These products offer designers an opportunity to improve existing concepts and take a different approach to new equipment design.

Swivels provide more design versatility, longer flex hose life, simplified plumbing, and ease of maintenance.

**Multiple Geometric Port Configurations**

"S" Series—Standard Duty Inline	"HS" Series—Heavy Duty Inline
"9S" Series—90° Pressure Balanced	"9SS" Series—Dual Plane
"18S" Series—Parallel Plane Swivel	"93S & 96S" Series 90° Flanged





P.O. Box 6479  
Fort Worth, TX 76115  
V. 817-923-1965  
www.hydraulicsinc.com

## Piezo-Electric Valves

Conventional applicators normally work require two valves: one to apply vacuum, the second to apply positive pressure. Piezo valves are much more accurate, faster and efficient, controlling pressure and vacuum with one valve.

**Polishing wafers.** Piezo valves are highly accurate and can quickly reach preselected setpoints. This makes them ideal for semiconductor applications where there is ample need to precisely meter small amounts of air to precisely machine the workpieces. When polishing wafers, for example, each wafer must be pressed against a rotating polishing table with accurately controlled pressure. In one step of the process, several diaphragm rings are pressed onto the wafers with varying amounts of force. These rings must be controlled precisely in terms of both vacuum and pressure. Piezo valves combine both these functions in a single compact valve.

**Medical ventilators.** Mobile ventilators for medical use must be light, compact and operate for a long time on battery power. Many patients depend on these units for oxygen as they sleep, so the machine should make as little noise

as possible. Piezo valves are already being used in these machines for their durability, accuracy, small size and power needs, and quiet operation.

**Surgical ophthalmology.** Piezo valves control pneumatically powered tools used in cataract surgery, one of the most common surgical procedures. This surgery is the only treatment for cataracts, the progressive or age-related clouding of the eye's lens. In the operation, the patient's clouded lens is removed and replaced with an artificial intraocular lens (IOL).

The surgical tools used are operated pneumatically. Piezo valves control pressure and



This Festo prototype for an emergency ventilator is based on piezo proportional-control-flow valves.



# CFC INDUSTRIAL TRAINING

## TRUSTED EXPERTS

World Class Engineering & Documentation  
of Fluid Power & Automation Systems

### Design

of automation systems &  
custom test equipment

### Reverse Engineering

& advanced documentation  
creation & services

### Engineering Support

when request overflow or  
expert guidance is required

### Troubleshooting

& start-up assistance

### Consultation

& expert witness



CFCINDUSTRIALTRAINING.com  
7042 Fairfield Business Drive  
Fairfield, Ohio 45014  
+1 513.874.3225  
info@cfcindustrialtraining.com

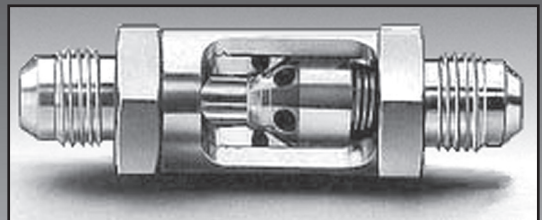

## Kep-O-seal® Inline Check Valves

The industry proven *Flexible Seal Seat™* combines metal-to-metal and soft seal seating to ensure superior leak-tight control and longer service life. Nine sizes with wide choice of connections and materials for system compatibility. Flows to 500 GPM. Pressure rated to 6,000 PSI; relief settings to 150 PSI.

For details visit: [www.kepner.com](http://www.kepner.com)

**KEPNER**  
PRODUCTS COMPANY  
(630) 279-1550 FAX (630) 279-9669 <http://www.kepner.com>



vacuum and are crucial for handling various liquids, including aqueous humour (the natural fluid in the eye) and substitute solutions (infusions). Piezo valves precisely meter and regulate the flow when replacing the aqueous humour.

**Car-seat comfort.** Piezo valves are hard at work silently filling and emptying air cushions underneath drivers and passengers. This makes the ride more comfortable. Air bladders built into seat side panels and backrests are filled as appropriate to the driving situation. The change in air pressures sent to various inflatable pillows is based on steering angle, lateral acceleration and travel speed. For example, the system inflates air chambers on the right side of the backrest more during left turns.

Thanks to their laundry list of properties, piezo valves are finding new uses in new and old products.

#### A VARIETY OF VALVES

Piezoelectric valves are versatile and can handle a wide variety of functions. Here are some examples from Festo Corp.

**2/2-way valve VEMR.** These valves have interchangeable seat inserts which lets them be used in a wide variety of applications because their pressure and flow rates are determined by the seat diameter. In oxygen therapy devices, for example, VEMR valves closely control oxygen supply and metering during inhalations. Combining a VEMR valve

with a flow sensor creates a proportional flow control valve. Two VEMR valves can be used with an additional pressure sensor and control electronic as a proportional pressure control valve.



This Festo 2/2-way proportional valve uses piezo technology.



The Festo VEMC incorporates a special bender actuator that uses differential movements to compensate for temperature-related errors.

**3/3-way valve VEMC or VEMP.** These valves are known as gap-transducer valves. They incorporate a special

bender actuator that uses differential movements to compensate for temperature-related errors. VEMC and VEMP are used in medical drainage devices but can also be used as switch valves to select between two different flow rates. VEMC and VEMP valves can be combined with a flow sensor and electronic control to create a proportional pressure regulator.

**3/3-way valve VEAA.** This valve, also known as a rocker transducer valve, has a trimorph transducer which lets it move in two directions, thus closing port P or R. Its range of vacuum supply pressure goes up to 12 bar, making it well suited for industrial apps with pressure regulation.

**Directly controlled proportional pressure regulator VEAB.** These are fully-fledged proportional valves which provide an output pressure via an integrated electronic unit with a pressure sensor. The setpoint can be specified as a voltage of 0 to 5 V or 0 to 10 V, or a current of 4 to 20 mA. The valve also generates a reference signal in the same range. The valve is compact for its flow rate of about 20 liters per minute, has response times of less than 10 msec, is highly accurate at regulating pressure, consumes little power and emits no switching noises. 

HANNES WIRTL is head of development for piezo valves and ULRICH SIXT is product manager for piezo valves at Festo AG & Co. in Germany.

FOR S.p.A. offers a full range of hydraulic tube fittings such as **ORFS, JIC, DIN, BSP, NPT, JIS, FLANGES, PLUGS, CHECK VALVES, TEST POINTS.**

FOR S.p.A. supplies both standard and customized parts.

**QUALITY • FLEXIBILITY • INNOVATION**



**FOR S.p.A.**

Strada Comunale Segadizzo, 2/A  
44028 Poggio Renatico  
Ferrara (Italy)  
Tel +39 0532 825211  
sales@forfittings.it  
[www.forfittings.it](http://www.forfittings.it)

## Useful Products

For more products, visit the Equipment Product Directory link at [www.hydraulicspneumatics.com](http://www.hydraulicspneumatics.com).

### Oxygen Control Valve



THE VEMD CONTROL VALVE is designed to proportionally control air flow in portable oxygen devices, ventilators, bioreactors and cell-culture fermenters. Piezo-based technology facilitates compact design, dynamic control and low energy consumption. The valve responds more than 30 times faster than comparable controllers to setpoint changes. Additional advantages include no-heat generation, silent operation and long service life. Festo offers an attractive price for the performance valve. Power consumption is rated at 1 W, which is ideal for prolonging battery life in portable oxygen systems. The VEMD can also be used in oxygen therapy machines designed for emergency ventilation and

aftercare. Since the VEMD is non-magnetic, it will not interfere with other medical devices.

**FESTO LIFETECH**, [www.festo.com](http://www.festo.com)

### Hydraulic Fluid

ENVIRON MV R is the first hydraulic fluid using ultra-pure severely hydrotreated base oils, so to meet the OECD 301B requirements for ready biodegradability. ENVIRON MV R combines select, ultra-pure, severely hydrotreated base oils with a premium ashless additive system to offer operators all the protection of a premium mobile and industrial hydraulic fluid while also being OECD 301B Readily Biodegradable to help protect sensitive environments. ENVIRON MV R provides excellent hydrolytic stability, something that is not possible with vegetable oil and synthetic ester-based alternatives, which readily degrade in the presence of water, reducing their service life and risking equipment damage and corrosion.

**PETROCANADA**, <https://lubricants.petro-canada.com>



### In-Line Conveyor



THE 2-1/2 NPT HEAVY DUTY THREADED LINE VAC is a powerful in-line conveyor that transports high volumes of material through ordinary pipe. Designed for rugged industrial applications, it has a hardened alloy construction that helps prevent premature wear when transporting abrasive or heavy materials like shot blast, tumbling media or metal fittings. These units feature large throat diameters that make it possible to convey more material over longer vertical and horizontal lengths. The conveying rate is typically twice that of ordinary air powered conveyors. Heavy Duty Threaded Line Vac conveyors eject a small amount of compressed air through directed nozzles to produce a vacuum on one end with high output flows on the other. Response is instantaneous. The

conveying rate is easily controlled using a pressure regulator on the compressed air supply. Seven sizes from 3/4 NPT to 3 NPT are available that fit popular pipe sizes.

**EXAIR**, <https://exair.co/45-lghdtlv>

### Controllers

THE HY-TTC 500 has received ISO 26262:2018 certification for functional safety up to ASIL C for TÜV Nord. This means that the same high level of functional safety needed for off-highway machinery such as cranes, construction equipment and material handling equipment can now be utilized as an off-the-shelf component in trucks, buses and municipal vehicles.

**HYDAC**, [www.hydac.com](http://www.hydac.com)



## Wireless ARM



A WIRELESS AUTOMATIC RECOVERY MODULE (ARM) has been developed for the AVENTICS G3 electronic fieldbus platform that makes it easy for technicians to perform pneumatic valve system commissioning and diagnostics from a mobile phone, tablet or laptop computer. The new wireless ARM module and AVENTICS G3 fieldbus platform are ideal for pneumatic valve system applications in the automotive, food and beverage, tire, packaging and metalworking industries. The wireless ARM module provides easy access to the AVENTICS G3 fieldbus platform's diagnostic and commissioning capabilities via an internal Wi-Fi access point and mobile website, even when the valve system is located inside a machine or on a ceiling. It offers the visual benefits of a hard-wired human machine interface

(HMI) at lower cost and with higher flexibility. The wireless ARM module generates error notification for alarms, voltage levels, short circuits, module errors, open load errors and distribution errors to reduce system downtime.

**EMERSON**, [www.Emerson.com/AVENTICS](http://www.Emerson.com/AVENTICS)

## Varnish Elimination

THE SERVICE-FRIENDLY VARNISH ELIMINATION UNIT (VEU) is used to prepare mineral oils and is particularly effective at removing oil-insoluble aging products (varnish) from said oils. Varnish deposits like to settle in hydraulic reservoirs and valves, or in the bearings of turbine lubrication systems, plastic injection molding machines, industrial forges and presses, and many other critical components, affecting the operating reliability and damaging critical hydraulic components in these multi-million-dollar systems. This is especially critical in machines that cost millions of dollars to operate each and every day and where equipment downtime can quickly out-cost a return on investment from fluid conditioning, which in many facilities is often less than six months. The unit is available with a water-cooled heat exchanger option for higher fluid temperature applications.



**SCHROEDER INDUSTRIES**, <https://schroederindustries.com/>

## Advertisers Index

<b>TOMPKINS INDUSTRIES, INC.</b> .....	<b>IFC</b>	<b>KEPNER PRODUCTS COMPANY</b> .....	<b>28</b>
<b>ABB MOTORS &amp; MECHANICAL, INC.</b> .....	<b>9</b>	<b>MAIN MANUFACTURING PRODUCTS</b> .....	<b>18</b>
<b>AIGNEP USA</b> .....	<b>26</b>	<b>MOCAP</b> .....	<b>26</b>
<b>AUTOMATION DIRECT</b> .....	<b>5</b>	<b>MOTION INDUSTRIES</b> .....	<b>7</b>
<b>C.MATIC SPA</b> .....	<b>14</b>	<b>MP FILTRI USA INC.</b> .....	<b>17</b>
<b>CFC INDUSTRIAL TRAINING</b> .....	<b>28</b>	<b>NOVOTECHNIK US INC.</b> .....	<b>19</b>
<b>DELTA COMPUTER SYSTEMS</b> .....	<b>10</b>	<b>PENINSULAR CYLINDER COMPANY</b> .....	<b>11</b>
<b>DEMACE SRL</b> .....	<b>6</b>	<b>RHEINTACHO MESSTECHNIK GMBH</b> .....	<b>27</b>
<b>DIESSE RUBBER HOSES SPA</b> .....	<b>3</b>	<b>TOMPKINS INDUSTRIES, INC.</b> .....	<b>18</b>
<b>FABCO-AIR INC.</b> .....	<b>25</b>	<b>TUSON CORPORATION</b> .....	<b>15</b>
<b>FOR S.P.A.</b> .....	<b>29</b>	<b>VELJAN HYDRAIR PRIVATE LIMITED</b> .....	<b>1</b>
<b>HYDAC TECHNOLOGY CORP.</b> .....	<b>IBC</b>	<b>VEST, INC.</b> .....	<b>23</b>
<b>HYDRAULICS INC.</b> .....	<b>27</b>		

# Advanced Hydraulics and Controls Make Calendering More Precise and Efficient

The precision and stability of the hydraulics and controls make them a more accurate and reliable way to handle calendering.

The calendering industry, like most others, is competitive, and calendering companies strive to keep up with, if not go beyond, the conventional technologies used in it to gain an edge. At JiangYin QinLi Rubber Machinery Co. Ltd. in China, management and engineers decided to upgrade their hydraulic actuators and controls to boost productivity and efficiency.

Calendering is the process by which textiles, plastics, metals and rubber are sent between a pair of hard rollers to smooth or finish them. The process was invented by Charles Goodyear, who used it on rubber in the 1800s. The Goodyear Tire & Rubber Co. remains a dominant player in the field of calendering to this day.

Across its rubber, plastic, metal and fiber film operations, JiangYin QinLi needs to deliver consistent quality while being the most economical supplier on the market. In calendering, quality generally stems from maintaining minimal thicknesses while preserving material tolerances. Doing so, however, makes mechanical calendering machines cumbersome. And machines that rely on electric motors to move rollers require manually adjusting the gap between rollers, as different materials require different roller spacing.

It is difficult to calibrate this gap on mechanical equipment, and making adjustments can take considerable time. Even under the best conditions, it is difficult to maintain a precise gap due to changing environmental conditions and constant wear on parts experience wear.

The arrival of hydraulic calendering over the last several years has opened the door to new ways to improve on mechanical calendering. With hydraulic calendering, rollers are moved by hydraulic cylinders, giving the cylinders a virtually infinite range of positionings to meet more demanding production needs.

For example, customers for calendered rubber sheets now expect available thicknesses to include those from 0.05 to 0.1 mm with tolerances of  $\pm 0.01$  to 0.005 mm. In some extreme cases, they need tolerances of  $\pm 0.0025$ . These tolerances are difficult to execute, but holding such tight tolerances saves on raw materials and reduces manufacturing costs while improving sales due to higher-quality product—at least for the few manufacturers able to manage it.

JiangYin QinLi took its technical specifications and reached out to Wuxi Forever in search of an end-to-end, best-in-class calendering solution. The integrator assisted in everything from

schematic design to post-deployment support and supplied everything from transducers and motion controllers to cylinders and hydraulic power units. Wuxi Forever even crafted an HMI terminal in which velocity, cylinder distance and required margin are all controlled by technician using a touchscreen.

JiangYin QinLi makes machines with two-, three- or four-roller calendering. Two-roller machines are often tasked with processing raw material while three- and four-roller versions process final products.

With Wuxi Forever's guidance, the company installed synchronous serial interface (SSI) position transducers (MDTs) from MTS and Wuxi Forever, and pressure sensors from Gefran. On a new two-roller extrusion machine, it added an RMC75E electrohydraulic motion controller with two-axis MA2 and AP2 expansion modules from Delta Computer Systems. Its new four-roller machine uses a right-axis Delta RMC151E with S2, H1 and U I/O modules to press either rubber or fiber films.

The design team chose Delta controllers based on its experience with ones that sequenced more smoothly between pressure and position control than other controllers. Many motion controllers suffer a position jump when transitioning between control modes (force versus position), and this deforms the calendered product. Delta controllers showed no such bounce. Additionally, Delta provided advanced control algorithms, including those using high-order gains to control the cylinder acceleration, as well as cylinder position and velocity. JiangYin QinLi engineers found it straightforward to use the RMCTools that came with the controller to create new algorithms.

The controller's built-in programming commands let the devices easily handle dual-loop control in which pressure is monitored while position is being controlled. The dual-loop control also makes smooth transitions between position/velocity and pressure/force modes. The Delta's integrated protocols facilitate seamless communication between the RMC and connected transducers, PC/PLCs and valves.

Hydraulic-controlled calenders are a clear trend in cutting-edge manufacturing. With modern motion control systems, they can deliver a wide array of benefits, says JiangYin QinLi's chief engineer YeGang Zhou. "Beyond rubber, our new calendering machines can also be used in semi-steel liner production which can have margins as small as 0.001 mm for position control of rollers moving 7 mm per second." 

# HYDAC SMART SOLUTIONS

SUSPENSION

COOLING

DRIVETRAIN

BRAKES

**CONTROLS**

STEERING

IMPLEMENTS

FILTRATION

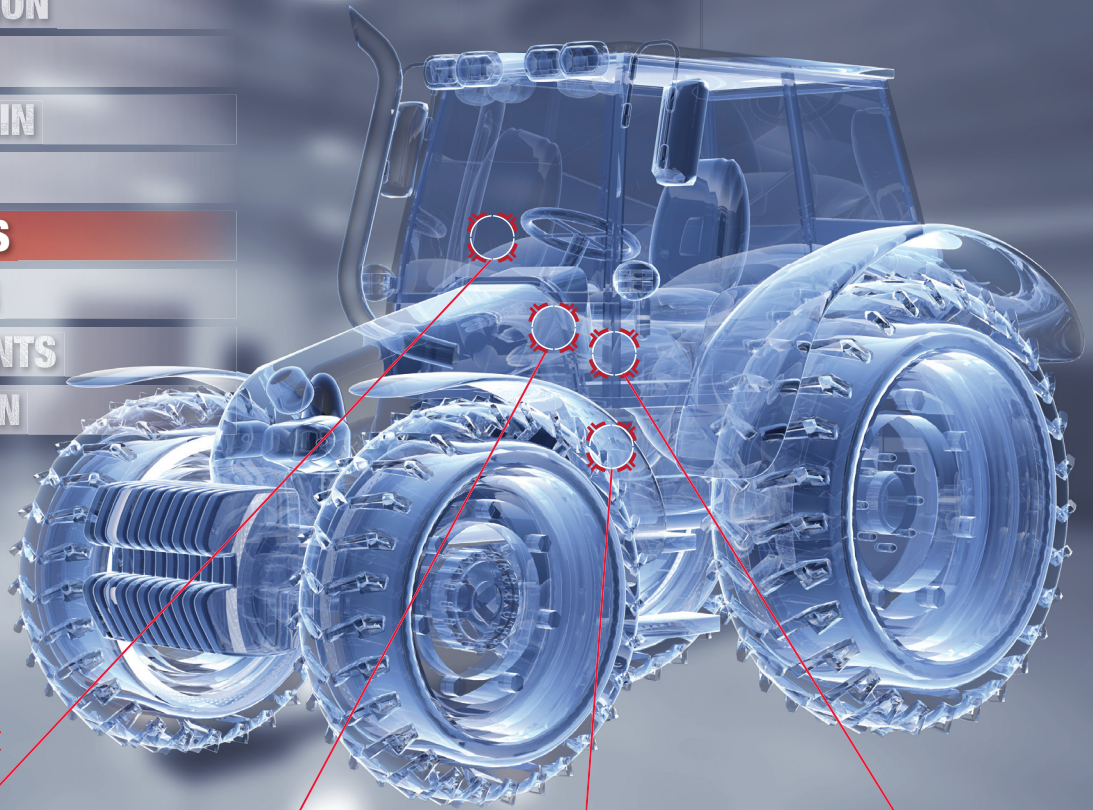

 **MATCH**  
BY HYDAC



Reduce your development time to automate your vehicle by up to 50%

HYDAC's MATCH development software



Provide your machine data seamlessly via the cloud

Rugged on-vehicle telematics system



Automate functions on your vehicle like virtual barriers or envelope control

Safe inclination, angle, position detection



Solve your safety and control needs for a wide range of applications

Configurable, safety rated controller

## We Optimize Machine Architecture!



**HYDAC** | INTERNATIONAL

[www.HYDAC-NA.com](http://www.HYDAC-NA.com) | [www.HYDAC.com](http://www.HYDAC.com)



# Hydraulics & Pneumatics

## A Human Commitment

Our goal is to ensure every subscriber reads every issue from cover to cover. For us, that means delivering consistent quality and extensive, engaging coverage for the people who depend on us.

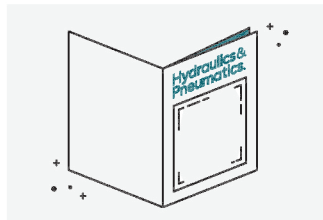
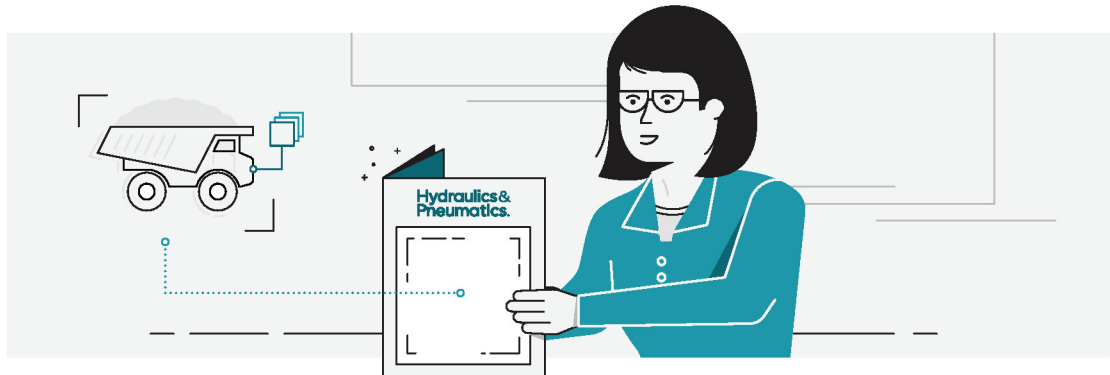

## OUR ORIGINAL CONTENT COVERAGE

- Mobile Hydraulics
- Pneumatics
- Industrial Hydraulics
- Electronic Sensing and Control
- Applications



## People Who Care

Bob Vavra

Senior Content Director, *Hydraulics & Pneumatics*

After a long career in the newspaper industry, Bob has been an editorial team leader for more than 20 years. During that time, he covered the global transition of the plant floor and its systems and managed several international automation conferences. Bob is also a sought-after Webcast moderator and event emcee, and has presided over events in the U.S., Germany and China.